

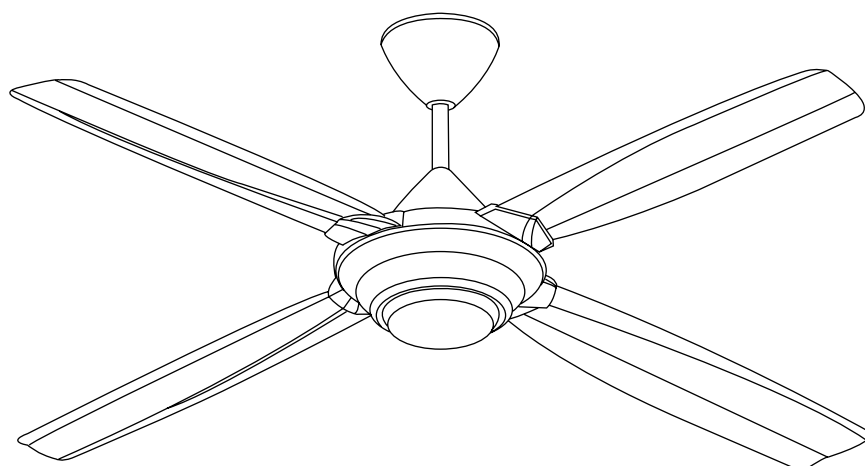

Operating and Installation Instructions

操作和安装指示



Ceiling Fan

吊扇

Model Number
型号
M56SR

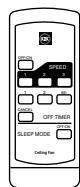

Thank you for purchasing KDK Ceiling Fan.
感谢您购买 KDK 吊扇。



Before operating this product, please read the instructions carefully, and keep this manual for future reference.
操作此产品前，请仔细阅读说明书，并保存本手册以作日后参考。





Contents / 目录

Page / 页数

Safety Precautions / 安全注意事项	2
Supplied Parts / 配备零件	5
How To Assemble / 如何组装	5
How To Install / 如何安装	9
How To Use / 如何使用	14
Maintenance / 维修	16
Product Specification / 产品规格	16

Safety Precautions / 安全注意事项

To avoid the possibility of causing injury to users or damage to properties, please follow all the explanations written below.
 为避免导致用户受伤或财物损坏的可能性，请遵守以下所述的所有指示。

 WARNING 警告	<p>A state that may be caused by the mishandling of products, which, if not avoided, may lead to the possibility of death or serious injury of users. 错误操作产品造成的情形，若不可避免可能导致用户死亡或严重受伤。</p>
 CAUTION 注意	<p>A state that may be caused by the mishandling of products, which, if not avoided, may result in the injury of users or property damage. 错误操作产品造成的情形，若不可避免可能导致用户受伤或财物损失。</p>
	<p>This symbol denotes an action that is COMPULSORY. 此符号表示有关行为是强制性的。</p>
	<p>This symbol denotes an action that is PROHIBITED. 此符号表示有关行为是被禁止的。</p>





 WARNING / 警告	
	<p>Follow strictly to all the instructions given in this manual for installation. Electrical wiring must be done by competent personnel. Installation must be done by a qualified personnel. Installation error can cause fire, electrical shock, Ceiling Fan drops and injuries. 安装时请严格地遵守本手册内所给的所有指示。 电线配线工作必须由能胜任的人员进行。 安装工作必须由符合资格的人员进行。 安装错误可以导致火灾、电击、吊扇掉落和受伤。</p>
	<p>Stop using the Ceiling Fan when any abnormality or failure occurs and turn "OFF" the Miniature Circuit Breaker (MCB). (Risk of smoke, fire, electric shock and drop) 当出现任何异常或故障时，停止使用吊扇并关闭 "OFF" 微型断路器 (MCB)。 (冒烟、火灾、电击、掉落的风险)</p>
 CAUTION / 注意	
	<p>This appliance is not intended for use by persons (including children) with reduced physical, sensory or mental capabilities, or lack of experience and knowledge, unless they have been given supervision or instruction concerning use of the appliance by a person responsible for their safety. Children should be supervised to ensure that they do not play with the appliance. 除非由安全监护人就本产品进行监督或指导，否则身体、感官或智力有功能障碍者，或者缺乏相关经验和知识的人士（包括儿童）请勿使用本电器。为了确保年幼的小孩不玩此电器，它们该受到监督。</p>
	<p>To avoid the possibility of causing injury to users or damage to properties, please follow all the explanation written in this manual. The manufacturer will not be responsible for any accidents and injuries caused by defective, deficient installation or installation which does not follow to instruction manual. 为避免导致用户受伤或财物损坏的可能性，请遵守本说明书内的所有指示。制造商对任何因不正确的安装或不按照说明书指示的安装所造成的任何意外和损伤将不负任何责任。</p>



 WARNING / 警		
<p>Switch off power supply and wait until the Blade is fully static, before cleaning or doing any maintenance jobs. 清扫或进行任何维修工作前，关闭所有电源并等待扇翼完全静止。</p> <p> </p> <p>Can cause Ceiling Fan to move suddenly, injuries and electrical shock. Kindly refer to your sales agent for repairing or maintenance issue. 可以导致吊扇突然转动、受伤和电击。请向您的经销商咨询有关修理或维修问题。</p>	<p>Do not dismantle the Ceiling Fan unless stated by this manual. Must use only supplied parts. 请勿拆除吊扇，除非此说明书指示。务必只使用附带的零件。</p> <p> </p> <p>Can cause fire, electrical shock, Ceiling Fan drops and injuries. 可以导致火灾、电击、吊扇掉落和受伤。</p>	<p>Avoid damage wire during installation eg. Deform due to heat, twist, bend, etc. 避免在安装时损坏电线，例如因热量、扭曲、弯曲造成的变形等等。</p> <p></p> <p>Can cause fire, explosion, short circuit and electrical shock. 这可导致火灾、爆炸、短路及电击。</p>
<p>Ensure the Pipe has been fully tighten to Motor Shaft. (Bolt tightening torque is 800~1200 N•cm) and Cotter Pin must fix into Bolt and bent. 确定将导管锁紧至发动机转动轴。(螺栓扭紧转矩是 800~1200 N•cm) 及开口销必须插入螺栓然后折弯。</p> <p></p> <p>Can cause injury if Ceiling Fan drops. 若吊扇掉落会导致受伤。</p>	<p>Ensure Hook Set can afford more than 10 times the Ceiling Fan weight. 确定吊钩组可以承受超过吊扇的 10 倍重量。</p> <p></p> <p>Can cause injury if Ceiling Fan drops. 若吊扇掉落会导致受伤。</p>	<p>Dismantle the broken or damage Ceiling Fan. 拆除破损或损坏了的吊扇。</p> <p></p> <p>Can cause Ceiling Fan drops and injuries. 可以导致吊扇掉落和受伤。</p>
<p>Tighten the Blade Screws firmly using a screwdriver. 使用螺丝起子将扇翼螺丝锁紧。</p> <p></p> <p>Can cause injury if Blade drops. 若扇翼掉落会导致受伤。</p>	<p>Do not use power supply other than rated voltage mentioned. 切勿使用本文指定的额定电压以外的电源。</p> <p></p> <p>Can cause injury if Ceiling Fan drops. 若吊扇掉落会导致受伤。</p>	<p>Do not sprinkle water to Ceiling Fan. Or, do not wet Ceiling Fan. 切勿向吊扇洒水。或者，切勿弄湿吊扇。</p> <p></p> <p>Can cause fire, explosion, short circuit and electrical shock. 这可导致火灾、爆炸、短路及电击。</p>
<p>Do not touch the Ceiling Fan while it is operating. 请勿在吊扇正在操作的时候触摸吊扇。</p> <p></p> <p>Can cause injury, damage and Ceiling Fan drops. 若吊扇掉落会导致受伤、损坏。</p>	<p>Overheating can cause electrical shock and fire. 过热可导致电击和火灾。</p> <p></p> <p>Can cause fire, explosion, short circuit and electrical shock. 这可导致火灾、爆炸、短路及电击。</p>	<p>Do not hang up to the Ceiling Fan. 切勿悬挂在吊扇。</p> <p> </p> <p>Can cause Ceiling Fan drops and injuries. 可以导致吊扇掉落和受伤。</p>
<p>Avoid installing the Ceiling Fan at oily and dusty places. 避免将吊扇安装在油腻及多尘的地方。</p> <p></p> <p>Can cause fire, explosion, short circuit and electrical shock. 这可以导致火灾、爆炸、短路和电击。</p>	<p>Do not install near a flammable area such as a gas cooker. 切勿安装在煤气灶等易燃地区附近。</p> <p> </p> <p>Can cause fire, explosion, short circuit and electrical shock. 这可导致火灾、爆炸、短路和电击。</p>	<p>Do not install the Ceiling Fan near chemicals and alkali. 切勿将吊扇安装在化学品和硷性物附近。</p> <p></p> <p>Can cause fire, explosion, short circuit and electrical shock. 这可以导致火灾、爆炸、短路和电击。</p>

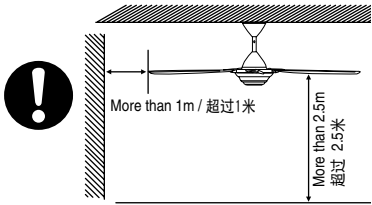

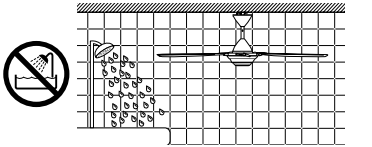

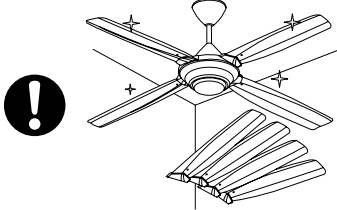
 CAUTION / 注意		
<p>Ceiling Fan must be mounted above 2.5m from the floor and 1m from the wall to the Blade. 吊扇必须挂在离地面 2.5 米以上的高度，而扇翼必须离开墙壁 1 米以上。</p>  <p>Can cause injury if hit by the Blades. Can cause unstable air flow and effect the Ceiling Fan to wobble. 若被扇翼击中，可以导致受伤。 可以导致不稳定气流和吊扇摇晃。</p>	<p>Avoid continuously exposure of direct wind from the Ceiling Fan. 避免长时间让吊扇直接吹着您。</p> <p></p> <p>It may cause discomfort. 这可能会导致不适。</p>	<p>Do not install at places where there is high vibration and impact. 切勿安装在高振动强度和高冲击强度的地方。</p> <p></p> <p>Can cause injury if Ceiling Fan drops. 若吊扇掉落会导致受伤。</p>
<p>Do not install the Ceiling Fan at a wet, high temperature and high humidity area such as shower room. 切勿将吊扇安装于潮湿、高温及高湿度的地方，例如浴室。</p>  <p>If an electrical current leakage occurs, it can easily cause electrical shock and fire. 若发生漏电，这很容易会导致电击和火灾。</p>	<p>This product is for in house use only. Do not install at a windy places. 本产品只供室内使用。切勿安装在多风的地方。</p> <p></p> <p>Can cause rusty, discolour, damage and injury. 这可导致生锈、褪色、损坏及受伤。</p> <p>Wipe away dirt with a clean soft cloth, ordinary soap and water to keep the fan clean. Do not use solvents (gasoline and petrol) or any other chemicals. 用干净的软布、普通肥皂和水抹去污渍以保持风扇的清洁。切勿使用溶剂（汽油和石油）或任何其他化学物品。</p> <p></p> <p>Can cause plastic part deformation and metal corrosion. 这可导致塑料部件变形及金属腐蚀。</p>	<p>Replace all the Blades if any of them broken or crack. 若任何一片扇翼断了或出现裂痕，请更换所有扇翼。</p>  <p>Vibration can cause the Ceiling Fan to fall. 震动会导致吊扇掉落。</p>



Supplied Parts / 配备零件

Parts / 零件	Pcs / 件
1. Motor Assembly / 发动机组件	1
2. Blade / 扇翼	4
3. Pipe / 导管	1
4. Lower Canopy / 下罩盖	2
5. Upper Canopy / 上罩盖	1
6. Remote Control / 遥控器	1
7. Batteries / 电池	2
8. Remocon Holder Set / 遥控器固定器组件	1
9. Part Set / 零件组	1

HOOK SET / 吊钩组

NOTE: These are not supplied.
注意：这些都不提供。

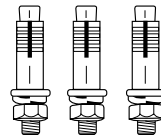

3 Suspension Bolts
3 个悬挂螺栓

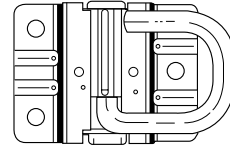

Hook Set
吊钩组

ATTENTION / 留意

Do not place the Ceiling Fan directly on the floor. Can cause scratches to the product.
切勿把吊扇直接放置在地上。这可导致产品被刮花。

How to Assemble / 如何组装

A) Insert Upper Canopy / 嵌入上罩盖

- 1 Remove Lower Canopy Screws at Pipe. Keep the screws for step D.2 at page 13.
从导管拆除下罩盖螺丝。保持这些螺丝以供第13页的步骤 D.2 使用。

Lower Canopy Screws /
下罩盖螺丝

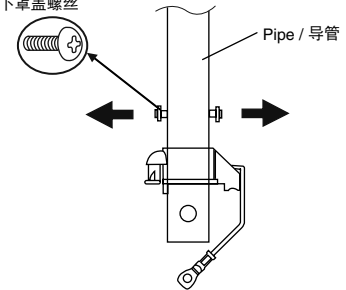

- 2 Insert Upper Canopy to Pipe.
将上罩盖嵌入导管。

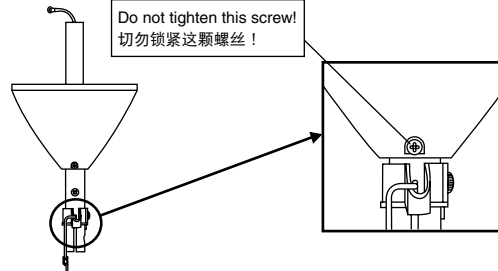
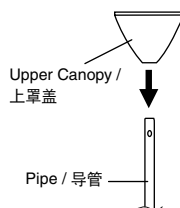

5

Check Point After Assemble / 组装后的检验点

Check / 检查

1. Insert Upper Canopy to Pipe and screw is not tightened. / 将上罩盖嵌入导管而不锁紧螺丝。



B) Assemble Pipe To Motor Assembly / 组装导管至发动机组件

- 1 Pull the power cord (from power supply) and insert into the Pipe hole as shown.
拉电缆（自电源）并如图所示将之插入导管孔。

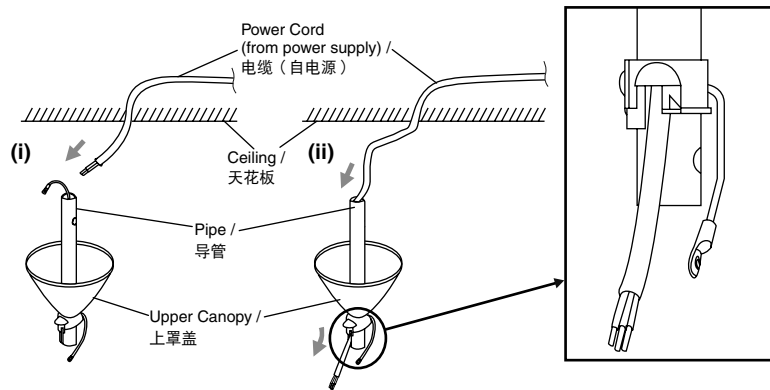

- 2 First, insert Cap to Motor Shaft. Next, insert Pipe to Motor Shaft.
首先，将盖子嵌入发动机转动轴。然后将导管插入发动机转动轴。

CAUTION / 注意



Do not remove the Switch Lever at Pipe.
Insert Pipe correctly to Motor Shaft.
Can cause product not operate if Switch has not been pressed down.

切勿拆除导管上的开关杆。
将导管正确地插入发动机转动轴。
若没压下开关可导致产品无法操作。



Do not press Switch with other object, except using the Switch Lever given.
Can cause fire, explosion, short circuit and electrical shock.

除了使用原有的开关杆以外，切勿与其他东西同时按压开关。
这可导致火灾、爆炸、短路及电击。

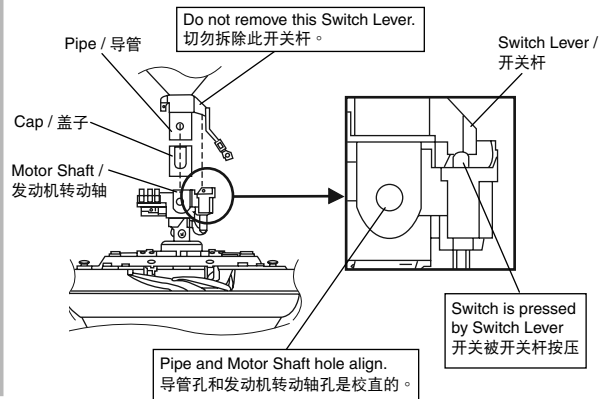

- 3 Fix the Pipe and Motor Assembly with
a) Ellipse Bolt, b) P-R Washer, c) Spring Washer,
d) Hexa Nut and e) Cotter Pin.
The Slit position of the Bolt should be top and bottom.
Bend the Cotter Pin at last.

使用以下物品安装导管与发动机组件

a) 椭圆螺栓、b) P-R 垫圈、c) 弹簧垫圈、d) 六角形螺帽
e) 开口销。

螺栓的缝隙必须位于顶部及底部。
最后折弯开口销。

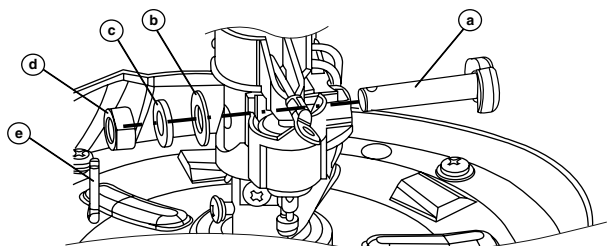

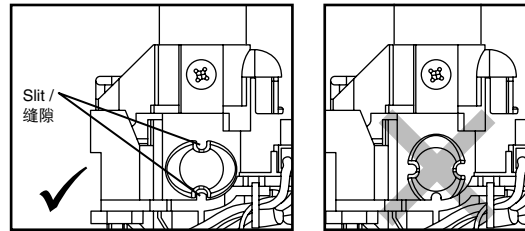
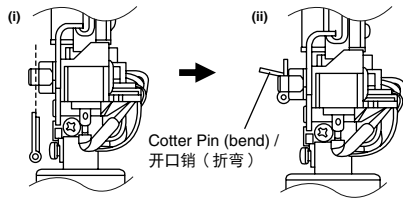

WARNING / 警告



Ensure the Pipe has been fully tightened to Motor Shaft.
(Bolt tightening torque is 800~1200 N•cm). Cotter Pin must fix into Bolt and bent.
Can cause injury if Ceiling Fan drops.
确定将导管锁紧至发动机转动轴。
(螺栓扭紧转矩是 800~1200 N•cm)。开口销必须插入螺栓然后折弯。
若吊扇掉落会导致受伤。

- 4** Remove Safety Wire Screw at Motor Shaft.
Fix the Safety Wire firmly to Motor Shaft with Safety Wire Screw. Safety Wire must not touch Teppan Cover.
拆除发动机转动轴上的保险线螺丝。使用保险线螺丝将保险线固定于发动机转动轴。保险线切勿触及铁板盖。

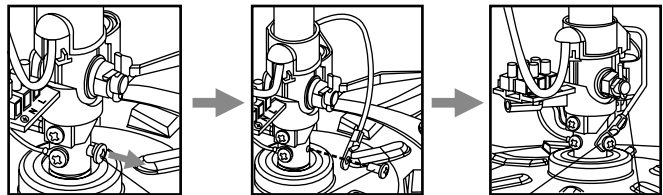

WARNING / 警告



Safety Wire must be fixed correctly and connected at all times.
Can cause injury if Ceiling Fan drops.
Ensure the Safety Wire does not touch the Motor surface.
保险线必须正确地安装以及在任何时候都连接接着。
若吊扇掉落会导致受伤。
确定保险线没有触及发动机表面。

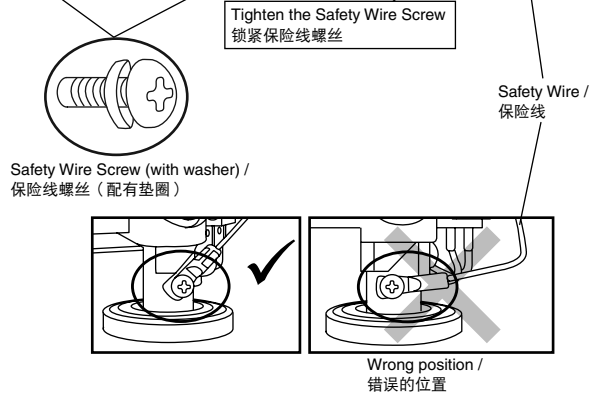

- 5** Connect the Power Cord to the 3 Pin Terminal.
连接电缆至 3 针端子。

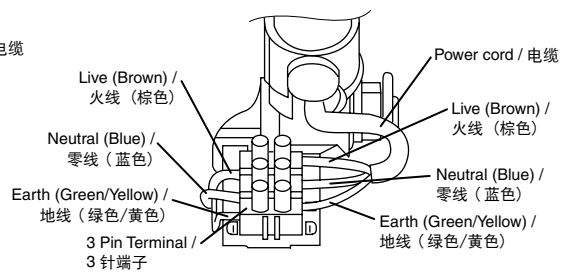
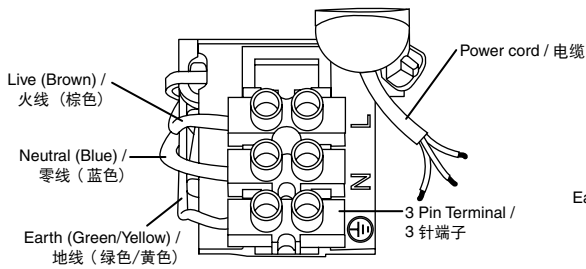

WARNING / 警告

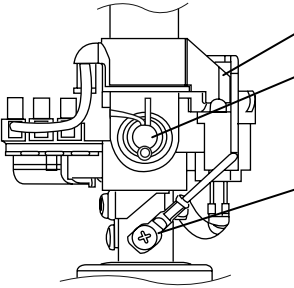

Electrical wiring must be done by competent personnel.
Can cause fire, electrical shock, Ceiling Fan drops and injuries.
电线配线工作必须由能胜任的人员进行。
这可导致火灾、电击、吊扇掉落及受伤。

Check Point After Assemble / 组装后的检验点		Check / 检查
	1. Switch Lever press the Switch. / 开关杆按压开关。	<input type="checkbox"/>
	2. Ellipse Bolt, P-R Washer, Spring Washer and Hexa Nut are firmly tightened and the Cotter Pin is inserted and bent for safety reason. / 基于安全理由，椭圆螺栓、P-R 垫圈、弹簧垫圈及六角形螺帽已锁紧，而开口销已插入并折弯。	<input type="checkbox"/>
	3. Safety Wire Screw is firmly tightened. / 保险线螺丝已锁紧。	<input type="checkbox"/>
	4. All wires are connected correctly by competent personnel. / 所有电线必须由能胜任的人员正确地连接。	<input type="checkbox"/>

C) Assemble Blades To Motor Assembly / 将扇翼组装到发动机组件

- 1 Remove Blade Screws (Silver colour screws, 8 pieces) from Motor Assembly. Do not remove the black colour screws. Fix the Blades firmly to Motor Assembly by Blade Screws. (Tightening torque for reference: 250-300 N•cm).
从发动机组件拆除扇翼螺丝（银色螺丝，8枚）。切勿取下黑色螺丝。使用扇翼螺丝将扇翼上紧到发动机组件上。（扭紧转矩基准：250-300 N•cm）。

WARNING / 警告

 Tighten the Blade Screws firmly using a screwdriver.
用螺丝起子将扇翼螺丝锁紧。
若扇翼掉落会导致受伤。

CAUTION / 注意

 Blade must be fixed correctly.
Can cause no air flow.
Can cause injury if Blades drops.
必须正确上紧扇翼。
这会导致没有气流。
若扇翼掉落会导致受伤。



 Do not remove the sticker.
Ensure the screws can be screwed securely.
Can cause injury if Blades drops.
切勿拆除贴纸。
确保螺丝被锁紧。
若扇翼掉落会导致受伤。

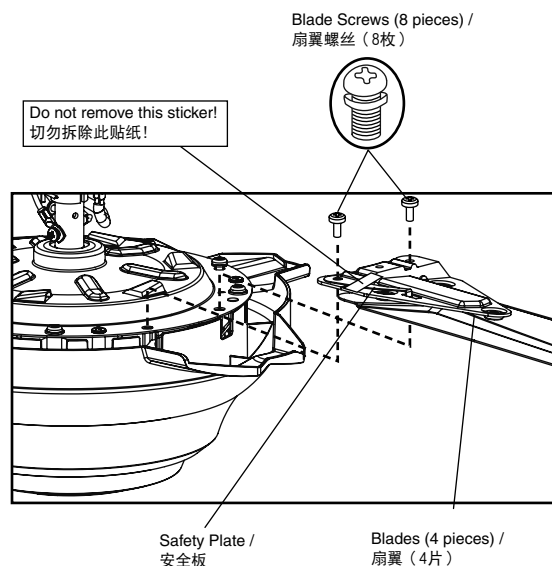

Check Point After Assemble / 组装后的检验点		Check / 检查
1. Blade Screws (8 pcs) for securing the Blades are tightly screwed. / 用于固定扇翼的扇翼螺丝（8枚）已锁紧。	<input type="checkbox"/>	

How to Install / 如何安装

A) Before Installation / 安装前

- 1** Before installation, check if the ceiling has Hook Set on it as shown. It should have at least 3 Suspension Bolts. If yes, please follow Step A2 (Installation A) and, A3 (Installation A) before proceeding to Step 5.

安装前，检查天花板是否有吊钩组如图所示。它至少有3个悬挂螺栓。

如果有，请按照步骤 5，然后再进行步骤A2的安装（安装 A），以及步骤A3（安装 A）。

If No, please follow Step A2 (Installation B), A3 (Installation B) and Step 4 before proceeding to Step 5.

如果没有，请按照步骤 5，然后再进行A2（安装 B），步骤A3（安装 B）和步骤 4 的安装。

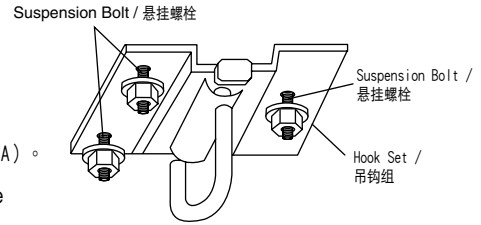

- 2** Drill hole. 钻孔。

CAUTION / 注意

This Ceiling Fan is specially design for mounting above 2.5m from the floor. Can cause injury if hit by the Blades.



Can cause unstable air flow and effect the Ceiling Fan to wobble. 本吊扇专门设计以挂在离地面 2.5米以上。

若被扇翼击中，可以导致受伤。可以导致不稳定气流及吊扇摇晃。



Ensure Hook can afford more than 10 times the Ceiling Fan weight. Can cause injury if Ceiling Fan drops.

确定钩子可以承受超过吊扇的 10 倍重量。若吊扇掉落会导致受伤。

INSTRUCTION A / 指示 A

Make holes on the concrete ceiling. Drill $\text{Ø} \ 6.5 \text{ mm}$ (depth 30 mm) for Carl Bolt 在混凝土天花板上钻孔。钻孔机：
 $\text{Ø} \ 6.5 \text{ 毫米}$ (深度 30 毫米) 给卡尔螺栓

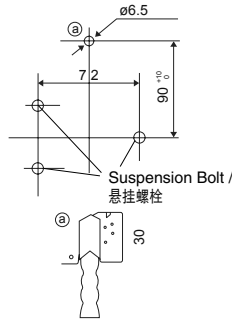

INSTRUCTION B / 指示 B

Make holes on the concrete ceiling. Drill $\text{Ø} \ 6.5 \text{ mm}$ (depth 30 mm) for Carl Bolt $\text{Ø} \ 12-12.5 \text{ mm}$ (depth 35-40 mm) for 3 Suspension Bolts (not supplied) 在混凝土天花板上钻孔。钻孔机：
 $\text{Ø} \ 6.5 \text{ 毫米}$ (深度 30 毫米) 给卡尔螺栓
 $\text{Ø} \ 12-12.5 \text{ 毫米}$ (深度 35-40 毫米) 给 3 个悬挂螺栓 (不提供)

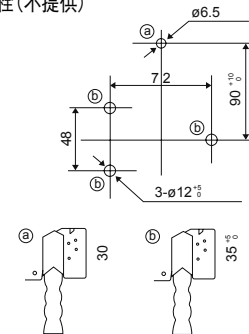

- 3** Install Bolt. 安装螺栓。

INSTRUCTION A / 指示 A

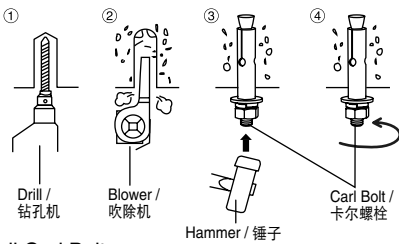

Install Carl Bolt.

安装卡尔螺栓。

1. Make holes on the concrete ceiling as shown in Step 2. 在混凝土天花板钻个孔如图所示步骤 2。
2. Use blower to remove dust in the holes. 使用吹除机清除孔内的灰尘。
3. Insert Carl Bolt to hole Ø . 将卡尔螺栓插入孔 Ø 。
4. Tighten the supplied Plain Washer, Spring Washer, Hexa Nut of the Carl Bolt. This is for making the Carl Bolt and fix to the ceiling. 锁紧卡尔螺栓附带的普通垫圈、弹簧垫圈、六角形螺帽。这是为了把卡尔螺栓固定在天花板上。

INSTRUCTION B / 指示 B

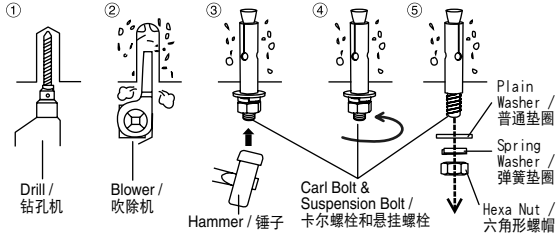

Install Carl Bolt and Suspension Bolts.

安装卡尔螺栓和悬挂螺栓。

1. Make holes on the concrete ceiling as shown in Step 2. 在混凝土天花板钻个孔如图所示步骤 2。
2. Use blower to remove dust in the holes. 使用吹除机清除孔内的灰尘。
3. Insert Carl Bolt to hole Ø Insert Suspension Bolts in hole Ø . 将卡尔螺栓插入孔 Ø 将悬挂螺栓插入孔 Ø 。
4. Tighten the supplied Plain Washer, Spring Washer, Hexa Nut of the Carl Bolt and Suspension Bolts accordingly. This is for making the Carl Bolt and Suspension Bolts fix to the ceiling. 锁紧卡尔螺栓和悬挂螺栓附带的普通垫圈、弹簧垫圈、六角形螺帽。这是为了把卡尔螺栓和悬挂螺栓固定在天花板上。
5. Remove Hexa Nut, Spring Washer, and Plain Washer from the Suspension Bolts. Make sure Suspension Bolts are remained strong on the ceiling. 将悬挂螺栓的六角形螺帽、弹簧垫圈和普通垫圈全部取出。确定悬挂螺栓仍然紧紧地固定在天花板上。

4 Install the Hook Set (For Instruction B only).
安装吊钩组 (只限于指示 B)。

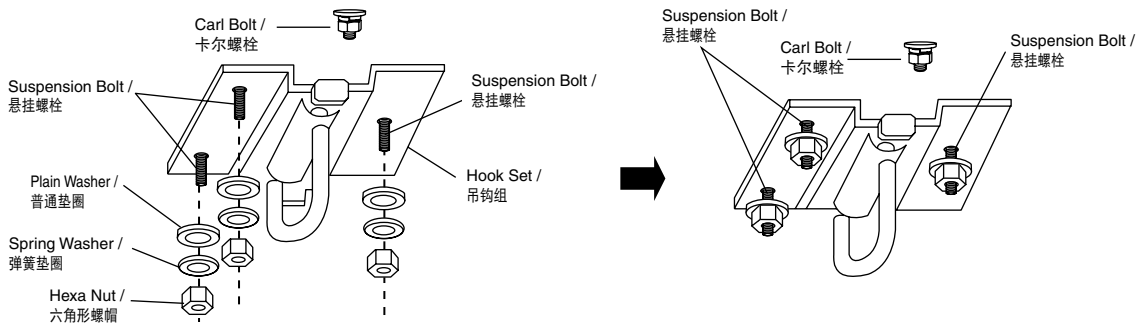

B) Install to Ceiling / 安装至天花板

1 Install to Ceiling.
安装至天花板。

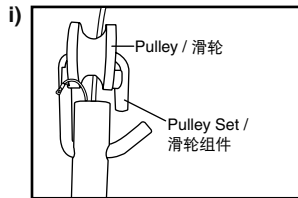

1st step / 步骤一
Take out Pulley Set from Parts Set, after that cross it to Pipe.
从零件组取出滑轮组件，随后将其转到导管上。

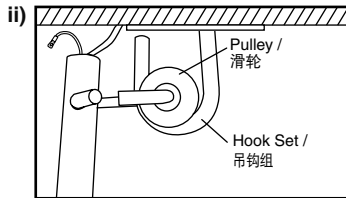

2nd step / 步骤二
Place the Pulley Set to the Hook Set as shown in the picture.
Make sure the Fan maintain straight to avoid the Blade from touching the ceiling during installation.
如图所示将滑轮组件置入吊钩组。
请确保风扇保持笔直以避免扇翼在安装过程中触碰天花板。

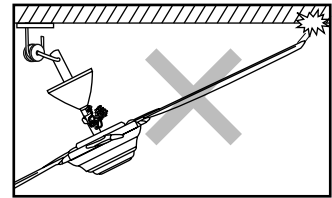

ALTERNATIVE METHOD / 其他方式

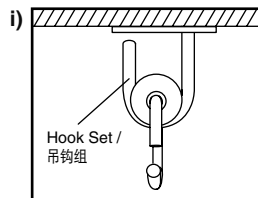

1st step / 步骤一
Place the Pulley Set to the Hook Set as shown in the picture.
如图所示将滑轮组件置入吊钩组。

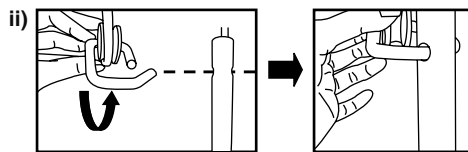

2nd step / 步骤二
Incline Pulley Set and install Ceiling Fan.
Make sure the Fan maintain straight to avoid the Blade from touching the ceiling during installation.
使滑轮组件倾斜，然后安装吊扇。
请确保风扇保持笔直以避免扇翼在安装过程中触碰天花板。

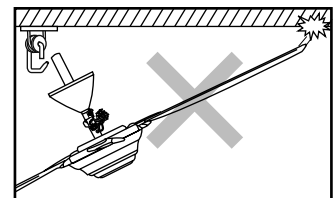

WARNING / 警告



Ensure Hook Set can afford more than 10 times the Ceiling Fan weight.
Can cause injury if Blades drops.
确定吊钩组可以承受超过吊扇的 10 倍重量。
若扇翼掉落会导致受伤。

CAUTION / 注意



Ensure Ceiling Fan is not tilted so that the Blade does not touch the ceiling during installation.
Can cause unstable air flow and effect the Ceiling Fan to wobble.
确保吊扇不倾斜，使扇翼在安装过程中不触及天花板。
可以导致不稳定气流和吊扇摇晃。

- 2** Remove Hexa Nut, Spring Washer, and Plain Washer from Carl Bolt. Loop the Safety Wire to the Hook Set and install Safety Wire as shown. 将六角形螺帽、弹簧垫圈和普通垫圈从卡尔螺栓全部取出。如图所示将保险线圈结至吊钩组并安装保险线。

WARNING / 警告

! Safety Wire must be fixed correctly and connected at all times. Can cause injury if Ceiling Fan drops. 保险线必须正确地安装以及在任何时候都连接着。若吊扇掉落会导致受伤。

CAUTION / 注意

⊘ The fan suspension system should be examined regularly at least once in two years. Can cause injury if Ceiling Fan drops. 必须至少每两年定期为风扇悬挂系统进行检查。若吊扇掉落会导致受伤。

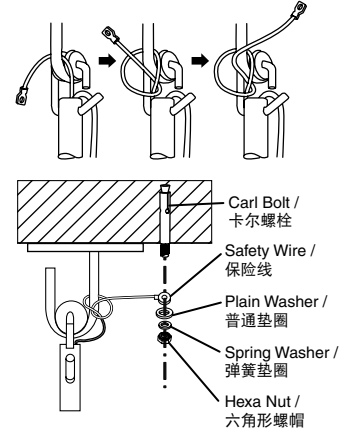

Check Point After Assemble / 组装后的检验点

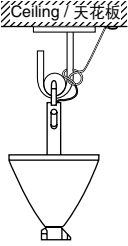
Check / 检查	Check / 检查
 <p>1. The Ceiling Fan is securely fixed onto the hanging hook. / 吊扇被稳固地安装在吊钩上。</p>	<input type="checkbox"/>
<p>2. The Safety Wire is securely fixed onto ceiling. / 保险线已稳定地安装在天花板上。</p>	<input type="checkbox"/>

C) Wiring Instruction / 配线指示

- 1** Connect power supply according to the Wiring Instruction below. 按照以下的配线指示接电源。

WARNING / 警告

! Electrical wiring must be done by competent personnel. Can cause fire, electrical shock, Ceiling Fan drops and injuries. 电线配线工作必须由能胜任的人员进行。这可导致火灾、电击、吊扇掉落及受伤。

WIRING DIAGRAM / 电线图

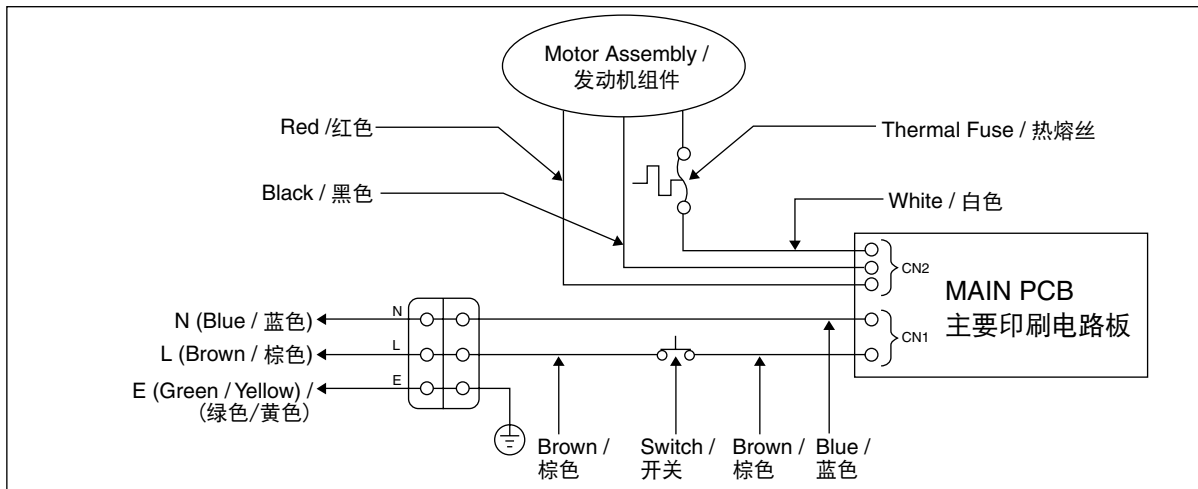

CONNECTING THE POWER SUPPLY / 连接电源

Only direct connection to wall switch is allowed. Please refer to figure below.
只可以直接连接至墙壁开关。请参考下图。

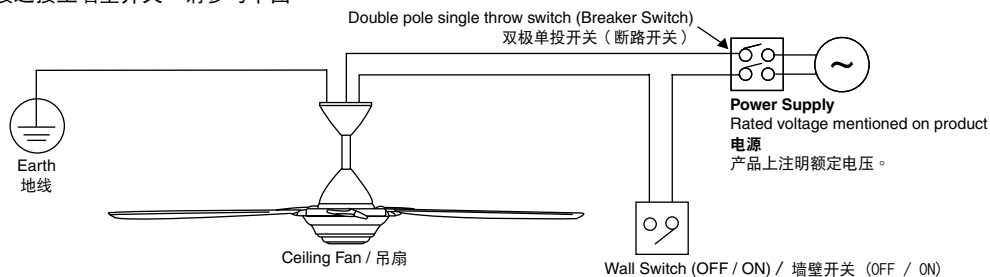

CAUTION / 注意



This product is not provided with cord and plug or with other means for connection from the supply. When connect or change the power cord or lead wire, it must be replaced by the competent personnel in order to avoid hazard. Please use 2271EC53(RVV) or thickness of tube is 1mm or above. (Other requirements such as diameter of lead wire, please use according to the regulation of the country).
本产品不提供电缆和插头或连接电源的其他装置。当连接或更换电缆或电线时必须由能胜任的人员进行以避免危险。请使用 2271EC53(RVV) 或厚度超过 1 毫米的导管。（其他要求，例如电线直径等等，请遵守相关国家的条例）。



This product should be installed with a double poles single throw switch (Breaker Switch) with minimum 3mm contact gap in the fixed installation circuit.
Do not connect this Ceiling Fan to dimmer switch or regulator. (It can damage the Ceiling Fan)
此产品必须在固定安装电路上装上触点间隙为最少 3 毫米的双极单投开关（断路器）。
切勿将此吊扇连接至调光开关或调节器。（这会损坏吊扇）

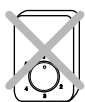

Regulator / 调节器



Dimmer Switch / 调光开关

Should there be a dimmer switch or regulator, disconnect it and reconnect the wiring as below.
若有调光开关或调节器，请按照下图拆除然后重新连接。

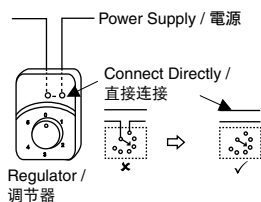

Regulator / 调节器

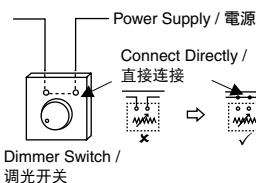

Dimmer Switch / 调光开关

ATTENTION / 留意

It is recommended to user, to install an OFF/ON switch on the wall for the Ceiling Fan, replacing existing regulator or new regulator point. If your Remote Control missing or misplaced, the Ceiling Fan can be switched on at pre-set speed 2.
建议用户将吊扇的 OFF/ON 开关安装在墙壁上，替换现有的调节器或新的调节点。若您的遥控器不见了，吊扇可以以预设速度 2 开启。

Check Point After Installation / 安装后的重点检查

1. The wiring is connected properly to the power supply.
电线已正确地连接了电源。

Check / 检查



D) Fix the Canopy / 安装罩盖

- 1 Adjust Upper Canopy position and fix Upper Canopy to Pipe firmly by screw.
The distance of Upper Canopy and ceiling is approximately 5mm.
调整上罩盖的位置，然后将上罩盖旋紧至导管。
上罩盖与天花板的距离大约是 5 毫米。

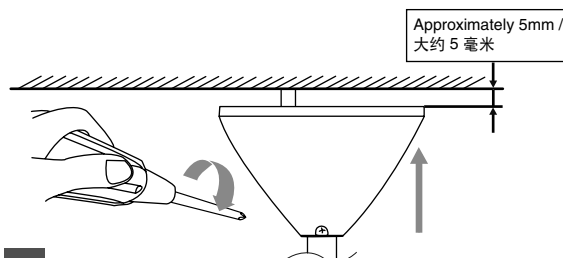

2 Fix the Lower Canopy by using the Lower Canopy Screw which was removed from Pipe at page 5 step A.1
 使用在第 5 页步骤 A.1 从导管拆除的下罩盖螺丝安装下罩盖。

- (i) Fix Lower Canopy B to Pipe by Lower Canopy Screw.
- (ii) Fix Lower Canopy A to Lower Canopy B with slide down as shown.
- (iii) Fix Lower Canopy A to Pipe by Lower Canopy Screw.
- (i) 使用下罩盖螺丝将下罩盖 B 固定于导管。
- (ii) 如图所示滑下下罩盖 A 以固定于下罩盖 B。
- (iii) 使用下罩盖螺丝将下罩盖 A 固定于导管。

CAUTION / 注意

Lower Canopy A and B must be fixed correctly.
 Can cause injury if Lower Canopy drops.
 下罩盖 A 与 B 必须正确地安装。
 若下罩盖掉落可以导致受伤。

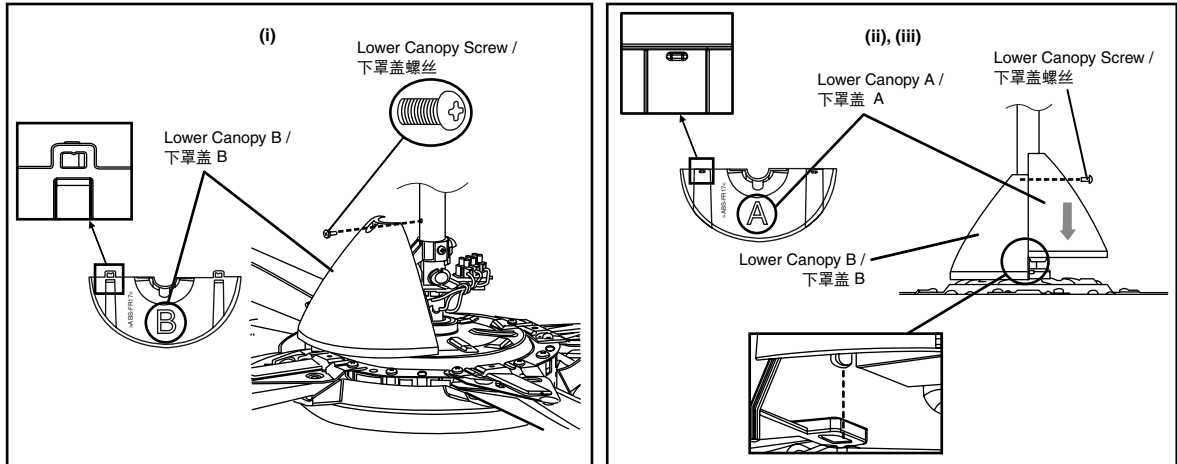

Check Point After Installation / 安装后的重点检查	
1. The Upper Canopy is securely fixed. 上罩盖已固定。	Check / 检查 <input type="checkbox"/>
2. The Lower Canopy is securely screwed. 下罩盖已锁紧。	<input type="checkbox"/>

E) Install Remocon Holder to Wall / 安装遥控器固定器至墙壁

- 1** Fix the Remocon Holder to wall as shown in figure below.
 * The Wall Plugs are not needed for wooden wall.
 将遥控器固定器固定于墙上，如下图所示。
 * 木墙不需使用墙壁插座。

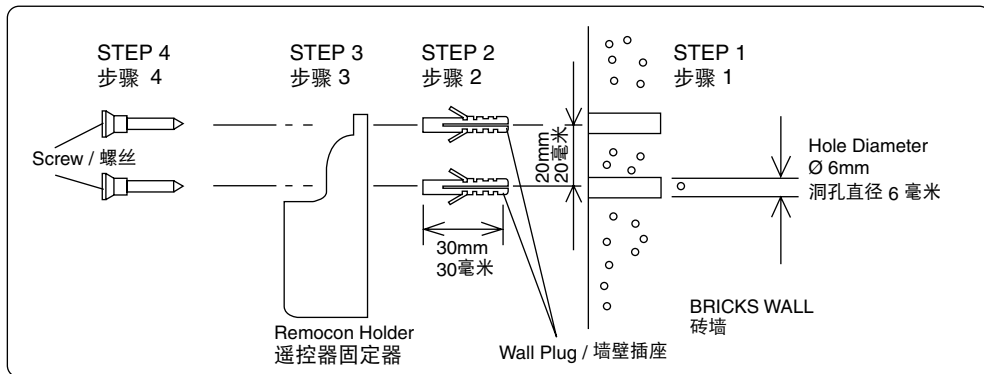

F) Final Confirmation / 最后确认

- 1 Measure the distance (L) using a measuring tape. Please adjust all the Blades to get the equal distance from ceiling to the Blade Tip (L). The distance (L) should have tolerance within 1mm. 使用卷尺测量距离 (L)。请调整所有扇翼，使天花板至扇翼末端 (L) 的距离相等。距离 (L) 的公差不能超过1毫米。

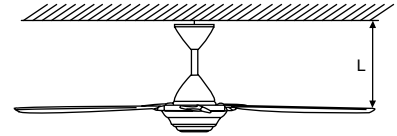

Pitching Method / 校准方法

Hold the Motor Assembly by hand and adjust the Blade (near the Blade Frame) carefully until the height (L) differences is ± 1 mm. 用手握住发动机组件，然后小心调整扇翼（靠近扇翼框架）直至高度 (L) 的差异为 ± 1 毫米。

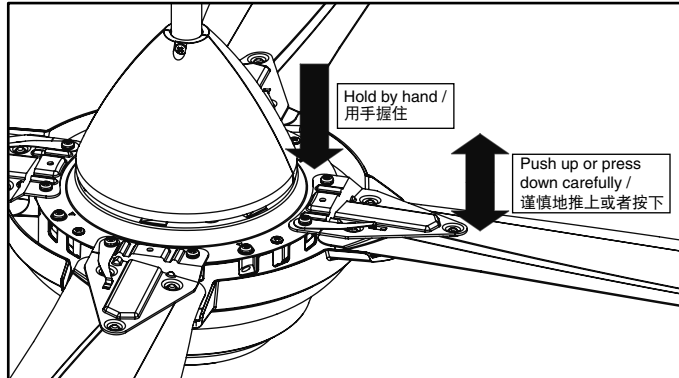

CAUTION / 注意



After installation make sure the Ceiling Fan does not wobble extremely. Can cause injury if Ceiling Fan drops. 安装后，请确定吊扇不会过度摇晃。若吊扇掉落会导致受伤。

How to Use / 如何使用

A) Before Use / 使用前

- Insert 2 pieces AA, R6P, R6, LR6 size Batteries and make sure the polarity direction is as shown in figure below.
- 插入 2 枚 AA, R6P, R6, LR6 尺寸的电池，并确保极性方向如下图所示。

1. Remove the cover

- Pull the flap to remove. 打开盖子
- 拉出盖口开关瓣以拆除。

2. Insert the Battery (2 pieces: AA, R6P, R6, LR6)

- ⊕ ⊖ Position should match. 插入电池 (2 枚: AA, R6P, R6, LR6)
- ⊕ ⊖ 位置必须对称。

3. Close the Cover

- Insert the protruding part (2 positions) into the Remote Control (2 holes), and press the flap. 盖好盖子
- 将突出的部分 (2 个位置) 插入遥控器 (2 个洞孔)，然后按下盖口开关瓣。

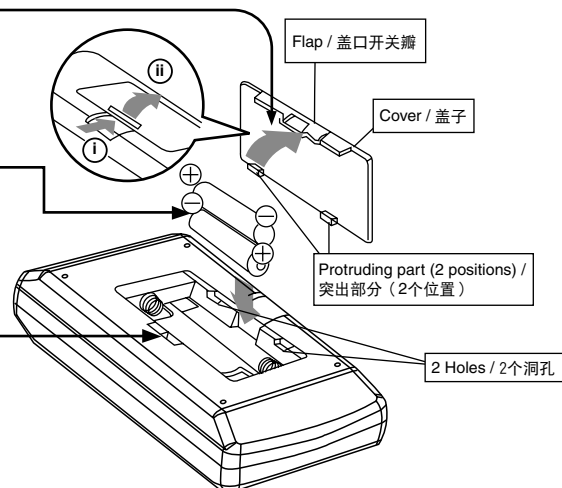

ATTENTION / 留意

- Please remove all Batteries before disposing the Remote Control.
- The life of Battery is about one year for a normal usage.
- 弃置遥控器之前请取出所有电池。
- 正常使用情况下的电池寿命约为1年。

B) Remote Control Coverage / 遥控器覆盖

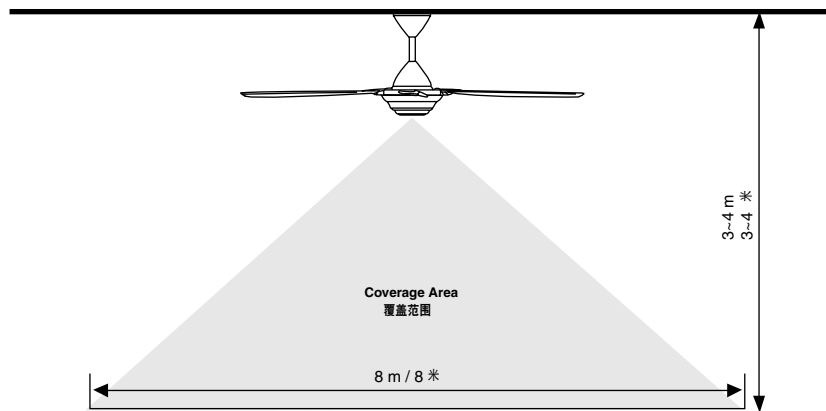

The figure above shows the best coverage area. The ideal ceiling height is 3~4m. The Remote Control must be pointed to the direction of the fan when in use.

上图显示最佳复盖范围。最佳天花板高度是3~4米。使用时，遥控器必须指向风扇的方向。

ATTENTION / 留意

The power consumption when the operation is turned off by the Remote Control is about 1W. It is recommended to switch off wall switch or breaker if Ceiling Fan is not in use for long period. This is for zero power consumption purpose.

操作被遥控器关闭时的电源消耗是大约1瓦特。
若将长时间不使用吊扇，建议您关闭墙壁开关或断路器。
以达到零电源消耗的目的。

C) How To Use Remote Control / 如何使用遥控器

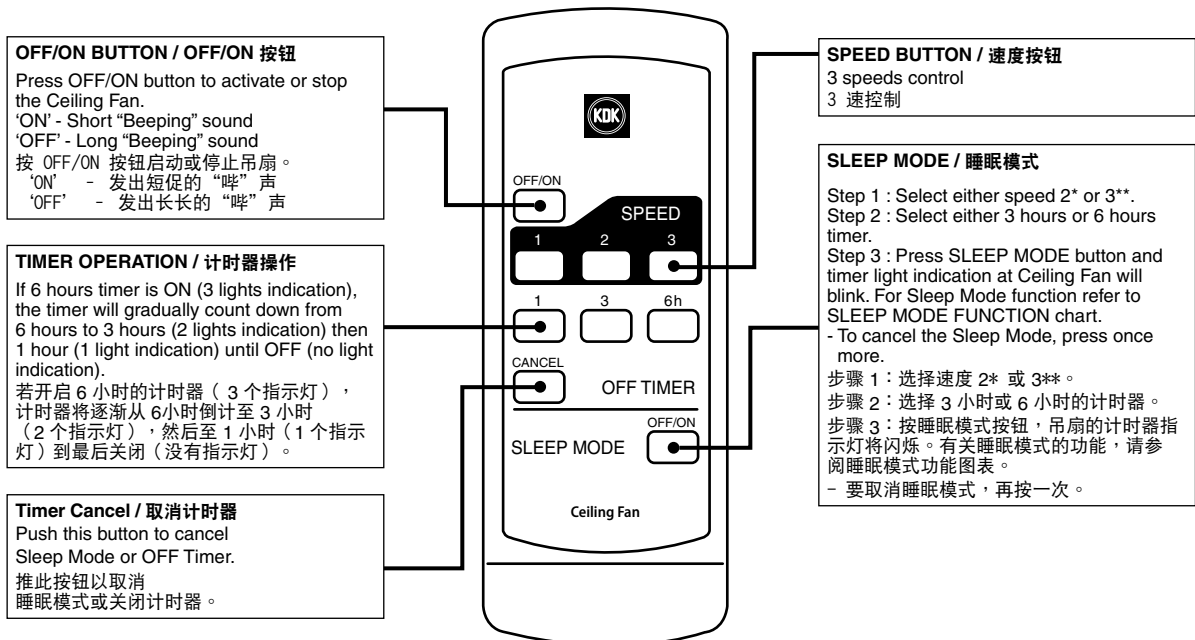

D) Timer / Sleep Mode Operation / 计时器/睡眠模式操作

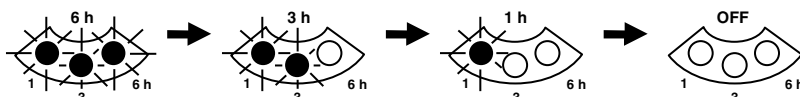

E) Sleep Mode Function / 睡眠模式功能

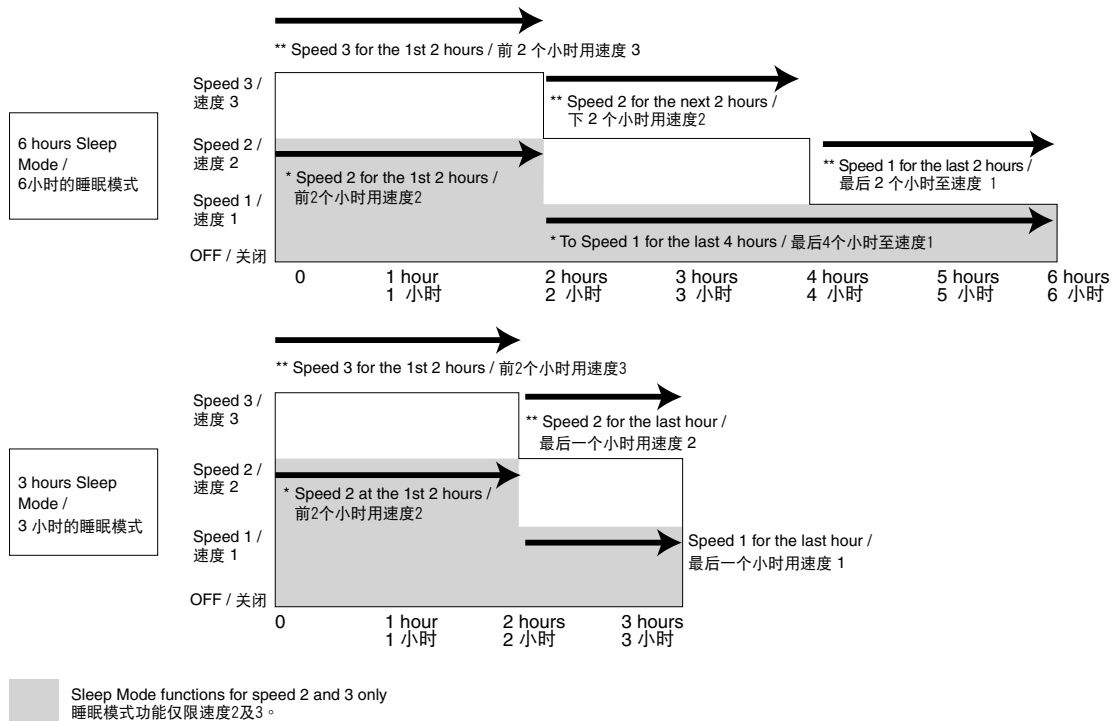

Maintenance / 维修

1. Check the fan condition annually. If a problem occurs, stop using the fan. Then refer to service, sales or maintenance shop.
Check points : Loosened Screws, Hexa Nut and Ellipse Bolt, Safety Wire condition, Motor Shaft damage, etc.
每年检查风扇的状况。如果出现问题, 停止使用有关风扇。然后质询服务、销售或维修商店。
检验点: 螺丝松脱、六角形螺帽和圆螺栓、保险线状况、发动机转动轴损坏等等。
2. Keep the fan clean. Wipe away dirt with a clean soft cloth, ordinary soap and water. Wipe it again to dry it. Do not use solvents (gasoline or petrol).
* Please do not bend the Blade while cleaning.
保持风扇清洁。用干净的软布、普通肥皂和水抹去污迹。再抹一次将之抹干。切勿使用溶剂(汽油和石油)。
* 清洗扇翼时请切勿折弯扇翼。
3. Do not paint the Blades. If damage, order new set of Blades (4 pieces) from service shop or sales shop.
切勿为扇翼涂漆。若扇翼损坏了, 请向服务商店或销售商店订购新的扇翼(4片)。
4. When referring to service, sales or maintenance shop, show this instruction to them and maintain correctly.
当您质询服务、销售或维修商店时, 请向他们出示此指示以便他们正确地进行维修。
5. If the product is broken or damage, please remove the fan from ceiling and replace with a new fan. This is to avoid the Ceiling Fan drops.
若产品已折断或损坏, 请从天花板上拆除风扇, 然后换上新的风扇。这是为了防止吊扇掉落。
6. Recommendation for the fan suspension system shall be examined at least once every two years.
建议每两年至少检查风扇悬挂系统一次。

Product Specification / 产品规格

VOLTAGE 电压	FREQUENCY 频率	WATTAGE 瓦特数	ROTATION (RPM) 旋转度 (RPM)		AIR VELOCITY 风速	AIR DELIVERY 送风量	NET WEIGHT 净重
VAC 伏特直流	Hz 赫兹	W 瓦特	LOW 低	HIGH 高	m/min 米/分钟	m ³ /min 立方米/分钟	kg 公斤
220-230	50	59-64	88-92	184-192	150-155	180-190	6.9