

Operating And Installation Instructions 操作和安裝指示

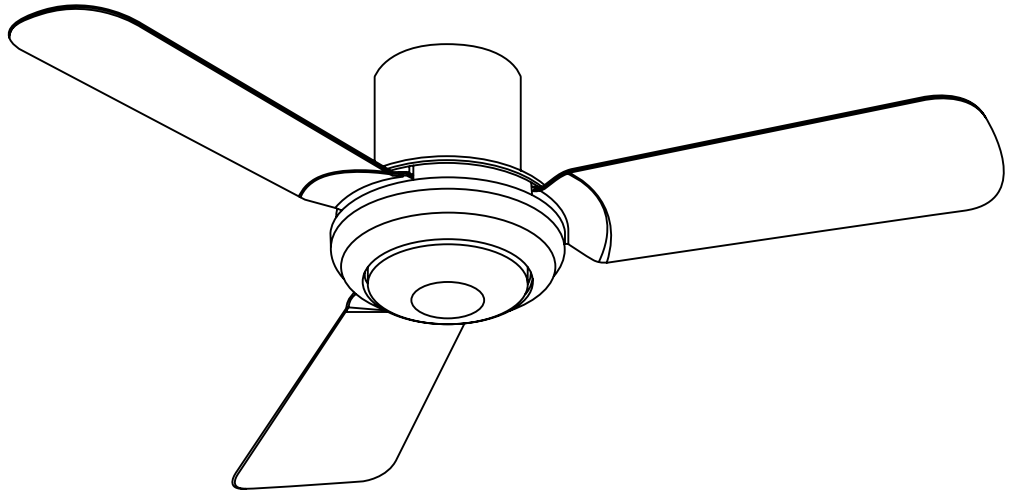

Ceiling Fan 吊扇

Model Number
型號

M11SU

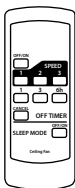

Thank you for purchasing KDK Ceiling Fan.
感謝您購買 KDK 吊扇。



Before operating this product, please read the instructions carefully, and keep this manual for future reference.

操作此產品前，請仔細閱讀說明書，並保存本手冊以作日後參考。





Contents / 目錄

Page / 頁數

Safety Precautions / 安全注意事項	2
Supplied Parts / 配備零件	5
How To Install / 如何安裝	5
How To Use / 如何使用	13
Maintenance / 維修	15
Product Specification / 產品規格	15

Safety Precautions / 安全注意事項

To avoid the possibility of causing injury to users or damage to properties, please follow all the explanations written below. 為避免導致用戶受傷或財物損壞的可能性，請遵守以下所述的所有指示。

 <p>WARNING 警告</p>	<p>A state that may be caused by the mishandling of products, which, if not avoided, may lead to the possibility of death or serious injury of users. 錯誤操作產品造成的情形，若不可避免可能導致用戶死亡或嚴重受傷。</p>
 <p>CAUTION 注意</p>	<p>A state that may be caused by the mishandling of products, which, if not avoided, may result in the injury of users or property damage. 錯誤操作產品造成的情形，若不可避免可能導致用戶受傷或財物損失。</p>
	<p>This symbol denotes an action that is COMPULSORY. 此符號表示有關行為是強制性的。</p>
	<p>This symbol denotes an action that is PROHIBITED. 此符號表示有關行為是被禁止的。</p>



WARNING / 警告



Follow strictly to all the instructions given in this manual for installation.
Electrical wiring must be done by competent personnel.
Installation must be done by a qualified personnel.
Installation error can cause fire, electrical shock, Ceiling Fan drops and injuries.
安裝時請嚴格地遵守本手冊內所給的所有指示。
電線配線工作必須由能勝任的人員進行。
安裝工作必須由符合資格的人員進行。
安裝錯誤可以導致火災、電擊、吊扇掉落和受傷。



Stop using the Ceiling Fan when any abnormality or failure occurs and turn "OFF" the Miniature Circuit Breaker (MCB).
(Risk of smoke, fire, electric shock and drop)
當發生任何異常或故障時，停止使用吊扇並關閉 "OFF" 微型斷路器 (MCB)。
(冒煙、火災、電擊、掉落的風險)



CAUTION / 注意



This appliance is not intended for use by persons (including children) with reduced physical, sensory or mental capabilities, or lack of experience and knowledge, unless they have been given supervision or instruction concerning use of the appliance by a person responsible for their safety. Children should be supervised to ensure that they do not play with the appliance.
除非由安全監護人就本產品進行監督或指導，否則身體、感官或智力有功能障礙者，或者缺乏相關經驗和知識的人士（包括兒童）請勿使用本電器。為了確保年幼的小孩不玩此電器，它們該受到監督。



To avoid the possibility of causing injury to users or damage to properties, please follow all the explanation written in this manual. The manufacturer will not be responsible for any accidents and injuries caused by defective, deficient installation or installation which does not follow to instruction manual.
為避免導致用戶受傷或財物損壞的可能性，請遵守本說明書內的所有指示。製造商對任何因不正確的安裝或不按照說明書指示的安裝所造成的任何意外和損傷將不負任何責任。



 WARNING / 警告		
<p>Switch off power supply and wait until the Blade is fully static, before cleaning or doing any maintenance jobs. 清掃或進行任何維修工作前，關閉所有電源並等待扇翼完全靜止。</p> <p> </p> <p>Can cause Ceiling Fan to move suddenly, injuries and electrical shock. Kindly refer to your sales agent for repairing or maintenance issue. 可以導致吊扇突然轉動、受傷和電擊。請向您的經銷商諮詢有關修理或維修問題。</p>	<p>Do not dismantle the Ceiling Fan unless stated by this manual. Must use only supplied parts. 請勿拆除吊扇，除非此說明書指示。務必只使用附帶的零件。</p> <p> </p> <p>Can cause fire, electrical shock, Ceiling Fan drops and injuries. 可以導致火災、電擊、吊扇掉落和受傷。</p>	<p>Avoid damage wire during installation eg. Deform due to heat, twist, bend, etc. 避免在安裝時損壞電線，例如因熱量、扭曲、彎曲造成的變形等等。</p> <p></p> <p>Can cause fire, explosion, short circuit and electrical shock. 這可導致火災、爆炸、短路及電擊。</p>
<p>Make sure all Screws, Nut, Bolt and connection are firmly tighten. 確保鎖緊所有螺絲、螺帽、螺柱和連接。</p> <p></p> <p>Can cause injury if Ceiling Fan drops. 若吊扇掉落會導致受傷。</p>	<p>Fix Hanger Plate Assembly correctly to the concrete ceiling and tighten Nut firmly. 將吊板組件正確地安裝於混凝土天花板，並鎖緊螺帽。</p> <p></p> <p>Can cause injury if Ceiling Fan drops. 若吊扇掉落會導致受傷。</p>	<p>Dismantle the broken or damage Ceiling Fan. 拆除破損或損壞了的吊扇。</p> <p></p> <p>Can cause Ceiling Fan drops and injuries. 可以導致吊扇掉落和受傷。</p>
<p>Tighten the Blade Screws firmly using a screwdriver. 使用螺絲起子將扇翼螺絲鎖緊。</p> <p></p> <p>Can cause injury if Blade drops. 若扇翼掉落會導致受傷。</p>	<p>Do not use power supply other than rated voltage mentioned. 切勿使用本文指定的額定電壓以外的電源。</p> <p></p> <p>Overheating can cause electrical shock and fire. 過熱可導致電擊和火災。</p>	<p>Do not sprinkle water to Ceiling Fan. Or, do not wet Ceiling Fan. 切勿向吊扇灑水。或者，切勿弄濕吊扇。</p> <p></p> <p>Can cause fire, explosion, short circuit and electrical shock. 這可導致火災、爆炸、短路及電擊。</p>
<p>Do not touch the Ceiling Fan while it is operating. 請勿在吊扇正在操作的時候觸摸吊扇。</p> <p></p> <p>Can cause injury, damage and Ceiling Fan drops. 若吊扇掉落會導致受傷、損壞。</p>	<p>Do not insert metal item in the Remote Control battery area with the Battery. 不要插入金屬物品在遙控器的電池與電池領域。</p> <p></p> <p>Can cause fire, explosion, short circuit and electrical shock. 這可導致火災、爆炸、短路及電擊。</p>	<p>Do not hang up to the Ceiling Fan. 切勿懸掛在吊扇上。</p> <p> </p> <p>Can cause Ceiling Fan drops and injuries. 可以導致吊扇掉落和受傷。</p>
<p>Avoid installing at oily and dusty places. 避免安裝在油膩及多塵的地方。</p> <p></p> <p>Can cause fire, explosion, short circuit and electrical shock. 這可以導致火災、爆炸、短路和電擊。</p>	<p>Do not install near a flammable area such as a gas cooker. 切勿安裝在煤氣灶等易燃地區附近。</p> <p> </p> <p>Can cause fire, explosion, short circuit and electrical shock. 這可導致火災、爆炸、短路和電擊。</p>	<p>Do not install near chemicals and alkali. 切勿安裝在化學物品和鹼性物品附近。</p> <p></p> <p>Can cause fire, explosion, short circuit and electrical shock. 這可以導致火災、爆炸、短路和電擊。</p>





CAUTION / 注意

Ceiling Fan must be mounted above 2.3m from the floor and 1m from the wall to the Blade.

吊扇必須掛在離地面 2.3米以上的高度，而扇翼必須離開牆壁 1米以上。

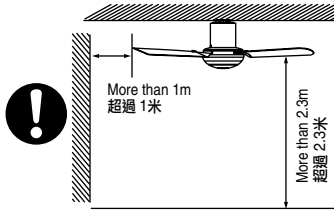

Can cause injury if hit the Blades.
Can cause unstable air flow and affect the Ceiling Fan to wobble.
若擊中扇翼，可以導致受傷。
可以導致不穩定氣流和吊扇搖晃。

Avoid continuously exposure of direct wind from the Ceiling Fan.
避免長時間讓風扇直接吹著您。



It may cause discomfort.
這可能會導致不適。

This product is for in house use only.
Do not install at a windy places.
本產品只供室內使用。切勿安裝在多風的地方。



Can cause rusty, discolour, damage and injury.
這可導致生鏽、褪色、損壞及受傷。

Do not install at places where there is high vibration and impact.
切勿安裝在高振動強度和高衝擊強度的地方。



Can cause injury if Ceiling Fan drops.
若吊扇掉落會導致受傷。

This product is suitable for flat concrete ceiling only.
Do not install at incline type ceiling.
本產品僅適合安裝在平坦的混凝土天花板。
切勿安裝在傾斜型的天花板。

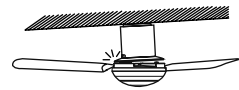

Can cause injury if Ceiling Fan drops.
若吊扇掉落會導致受傷。

Do not install at a wet, high temperature and high humidity area such as shower room.
切勿安裝於潮濕、高溫及高濕度的地方，例如浴室。

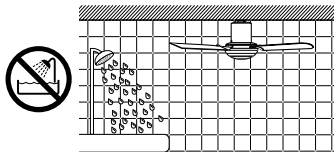

If an electrical current leakage occurs, it can easily cause electrical shock and fire.
若發生漏電，這很容易會導致電擊和火災。

Wipe away dirt with a clean soft cloth, ordinary soap and water to keep the fan clean. Do not use solvents (gasoline and petrol) or any other chemicals.
用乾淨的軟布、普通肥皂和水抹去汙跡以保持風扇的清潔。切勿使用溶劑（汽油和石油）或任何其他化學物品。



Can cause plastic part deformation and metal corrosion.
這可導致塑料部件變形及金屬腐蝕。

Replace all the Blades if any of them broken or crack.
若任何一片扇翼斷了或出現裂痕，請更換所有扇翼。

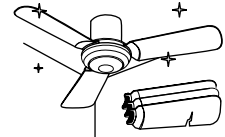

Vibration can cause the Ceiling Fan to fall.
震動會導致吊扇掉落。

Supplied Parts / 配備零件

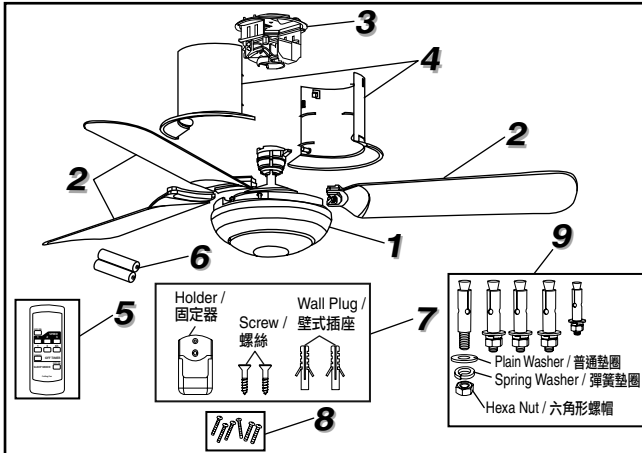

Parts / 零件	Piece(s) / 件
1. Motor Assembly / 發動機組件	1
2. Blade / 扇翼	3
3. Hanger Plate Assembly / 吊板組件	1
4. Canopy / 罩蓋	2
5. Remote Control / 遙控器	1
6. Batteries / 電池 (AA, R6P, R6, LR6)	2
7. Remocon Holder Set / 遙控器固定器組件	1
8. Blade Screw Set (6 pieces Screw) / 扇翼螺絲組件 (6 枚螺絲)	1
9. Carl Bolt Set (5 pieces Carl Bolt) / 卡爾螺栓組 (5 枚固定螺栓)	1

NOTE / 備註

Do not place the Ceiling Fan directly on the floor. / 切勿把吊扇直接放置在地上。
Can cause scratches to the product. / 這可導致產品被刮花。

How To Install / 如何安裝

A) Install Blade Assembly To Motor Assembly / 安裝扇翼至發動機組件

- 1** Take out Hanger Plate Assembly from the Upper Pack. Put the Motor Assembly on the round portion of the Upper Pack to assemble fan as shown.
從上部組件拆下吊板組件。
如圖所示將發動機組件放在上部組件的圓形部分上以組裝風扇。

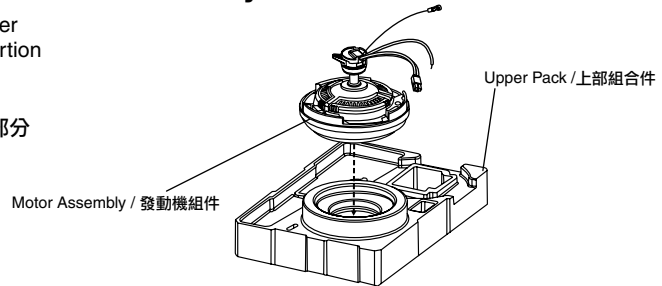

- 2** Assemble the Blades as shown. Take Blade Screws from the Part Set and tighten it firmly for fixing Blades (3 pieces). Screw: (M5 x 25L: Pan Type Screw) 6 pieces, (Tightening torque for reference: 250~300 N•cm).
如圖所示安裝扇翼。從零件組拿出扇翼螺絲並將之鎖緊以安裝扇翼 (3 片)。
螺絲: (M5 x 25L: 盆狀螺絲) 6 枚, (扭緊轉距基準: 250~300N•cm)。

WARNING / 警告

- !** Tighten the Blade Screws firmly using a screwdriver.
用螺絲起子將扇翼螺絲鎖緊。
若扇翼掉落會導致受傷。

CAUTION / 注意

- !** Blade must be fixed at correct position.
扇翼必須安裝在正確的位置。
Blade Cover / 扇翼蓋
- Can cause no air flow.
這會導致沒有氣流。
- Can cause injury if Blades drop.
若扇翼掉落會導致受傷。

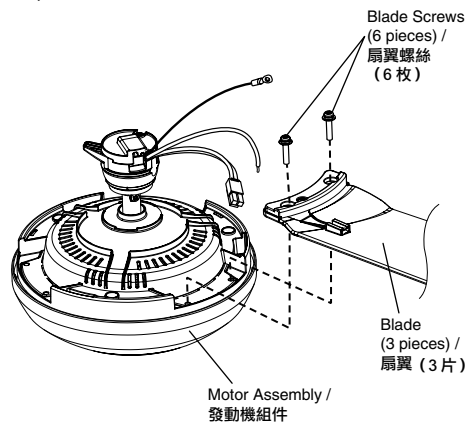

Check Point After Install / 安裝後的檢驗點

1. Ensure the Screws (6 pieces) for securing the Blade are tightly screwed. / 確用作鎖定扇翼的螺絲 (6枚) 已被鎖緊。

Check / 檢查

B) Install Hanger Plate Assembly to Concrete Ceiling / 安裝吊板組件至混凝土天花板

- 1** Make 5 holes on the concrete ceiling. 4 holes (no. 2, 3, 4, 5) with diameter 8.5mm (depth 45mm) and hole no. 1 with diameter 6.5mm (depth 30mm).
 在混凝土天花板鑽 5 個孔。4 個孔 (2, 3, 4, 5 號) 直徑 8.5 毫米 (深度 45 毫米) 和 1 號孔直徑 6.5 毫米 (深度 30 毫米)。
 (Hole no.1 is for Safety Wire).
 (1 號孔用於保險線)。

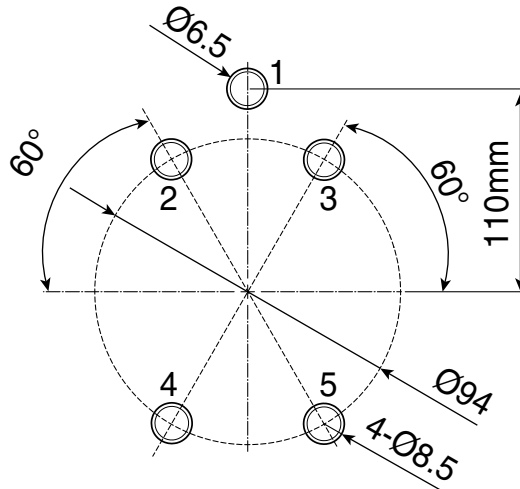

2 Install Carl Bolt. 安裝卡爾螺栓。

1. Drill holes on the concrete ceiling.
在混凝土天花板鑽孔。
2. Use blower to remove dust in the holes.
使用吹除機清除孔內的灰塵。
3. Insert the Carl Bolt.
插入卡爾螺栓。
4. Tighten the supplied Plain Washer, Spring Washer, Hexa Nut to all 5 Carl Bolts. This is for making the Carl Bolt stuck to the ceiling.
鎖緊附帶的普通墊圈、彈簧墊圈、六角形螺帽至所有 5 枚卡爾螺栓。這把卡爾螺栓固定在天花板。
5. Remove Hexa Nut, Spring Washer, and Plain Washer from hole no. 2, 3, 4 and 5 Carl Bolt. Make sure Carl Bolt is remained strong on the ceiling.
將六角形螺帽、彈簧墊圈和普通墊圈從 2、3、4 號孔取出並拆除 5 枚卡爾螺栓。確定卡爾螺栓仍然緊緊地固定在天花板上。

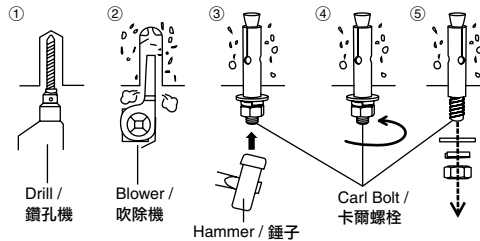

- 3** Remove Hanger Supporter Screws and Hanger Supporter from the Hanger Plate Assembly. Keep Hanger Supporter Screws & Hanger Supporter for step C-4 (Page 9).
 將吊架支架螺絲和吊架支架從吊板組件拆除。保持吊架支架螺絲&吊架支架以用於步驟 C-4 (第 9 頁)。

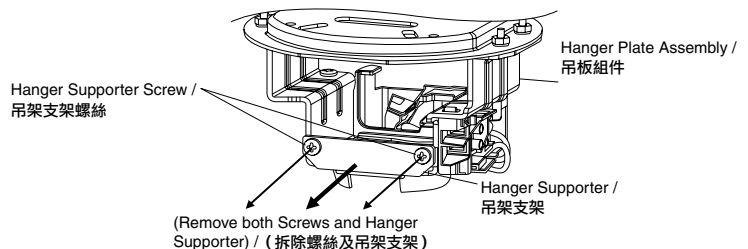

- 4** Fix the Hanger Plate Assembly to the concrete ceiling and tighten the supplied Carl Bolt, Plain Washer, Spring Washer and Hexa Nut referring to the numbers given. No.1 Carl Bolt is used for Safety Wire.
- 安裝吊板組件至混凝土天花板並依照所給的號碼鎖緊附帶的卡爾螺栓、普通墊圈、彈簧墊圈及六角形螺帽。1 號卡爾螺栓用於保險線。

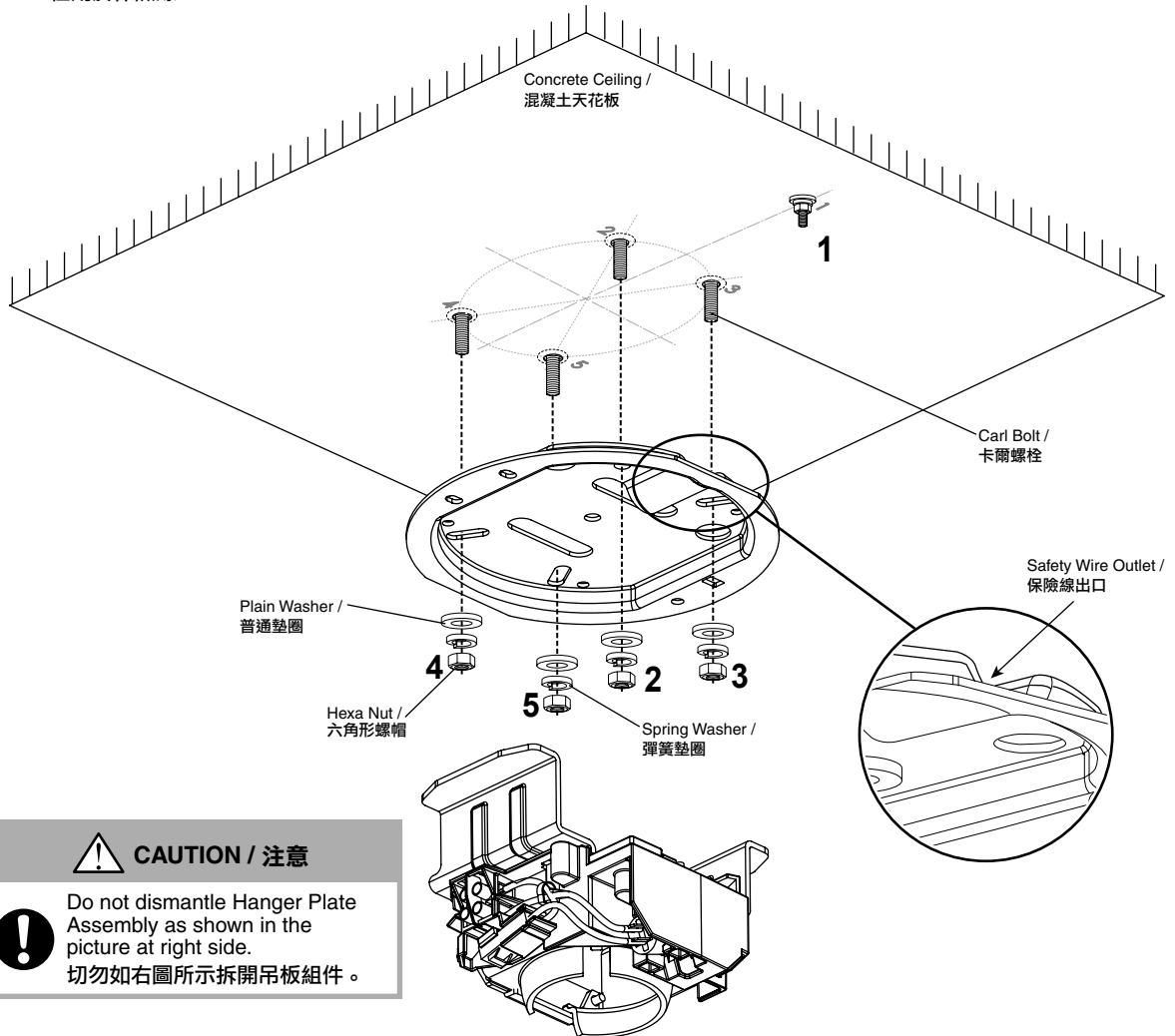

< This diagram is for viewing purpose only. > / <此圖只供參考。>

WARNING / 警告

- !** Fix Hanger Plate Assembly correctly to the concrete ceiling, and tighten Hexa Nut firmly. Can cause injury if Ceiling Fan drops.
將吊板組件正確地安裝於混凝土天花板，並鎖緊六角形螺帽。若吊扇掉落會導致受傷。

Check Point After Install / 安裝後的檢驗點

1. Ensure the Hanger Plate Assembly is securely fixed on the concrete ceiling. The Carl Bolt, Plain Washer, Spring Washer and Hexa Nut should be firmly tightened for the safety reason. / 確定吊板組件已鎖緊在混凝土天花板。基於安全理由，卡爾螺栓、普通墊圈、彈簧墊圈及六角形螺帽必須鎖緊。

Check / 檢查



C) Install Motor Assembly to Hanger Plate Assembly / 安裝發動機組件至吊板組件

- 1** Insert Ball Joint into the Hanger Plate Assembly.
將球形接頭插入吊板組件。

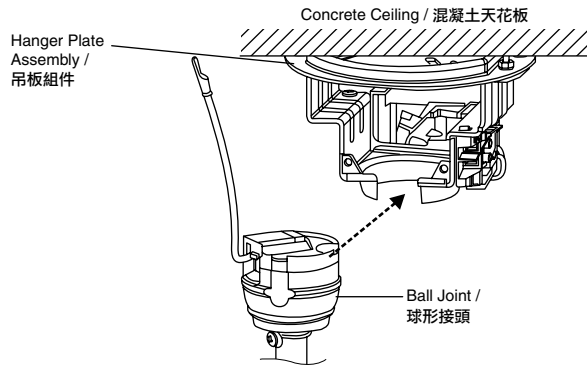

- 2** Adjust the Ball Joint to insert the Hanger Guide Rib into its slot. Refer to **A** in the illustration below. Make sure the Ball Joint Holder is placed onto the Switch Cover. Refer to **B** in the illustration below. 調整球形接頭以將吊架導向擋邊插入其狹槽。如下圖所指的 **A**。確定將球形接頭固定點放在開關罩上。如下圖所指的 **B**。

CAUTION / 注意



Fix Ball Joint correctly to Hanger Plate Assembly. Can cause product not operate if Switch Cover has not been pressed down.
正確地將球形接頭安裝至吊板組件。若沒壓下開關罩可導致產品無法操作。



Do not push Switch Cover with other object, except using Ball Joint given. Can cause fire, explosion, short circuit and electrical shock.
除了所提供的球形接頭，切勿使用其他物體推開關罩。這可以導致火災、爆炸、短路和電擊。

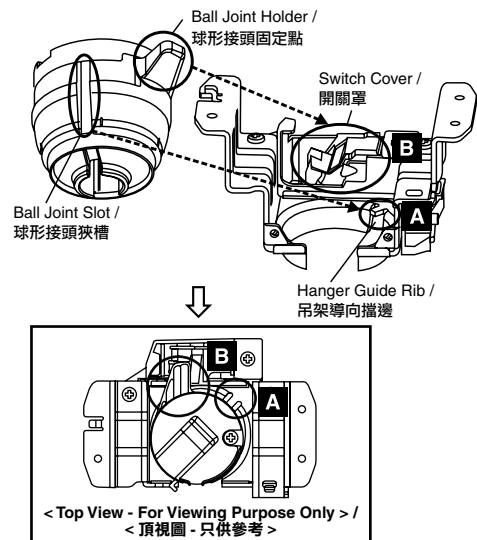

- 3** Remove Hexa Nut, Spring Washer, and Plain Washer from hole no. 1 Carl Bolt. Pass Safety Wire through Safety Wire Outlet. Fix Safety Wire to no. 1 Carl Bolt as shown. Tighten the removed Carl Bolt, Plain Washer, Spring Washer and Hexa Nut. 將六角形螺帽、彈簧墊圈和普通墊圈從1號孔卡爾螺栓取出。將安全線通過保險線出口。如圖所示，將保險線固定至1號卡爾螺栓。鎖緊之前拆下的卡爾螺栓、普通墊圈、彈簧墊圈和六角形螺帽。

CAUTION / 注意



Safety Wire must be fixed correctly. Can cause injury if Ceiling Fan drops.
保險線必須正確地安裝。若吊扇掉落會導致受傷。

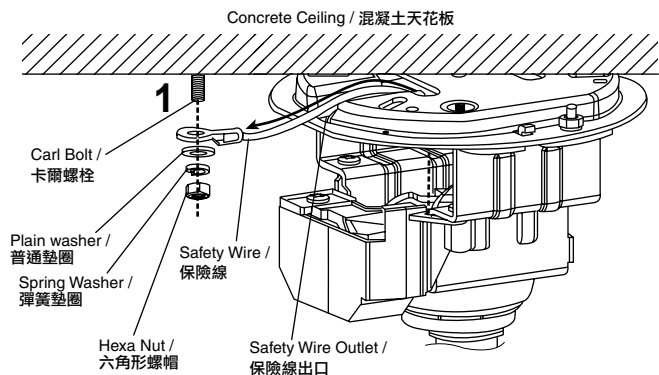

- 4** Install back Hanger Supporter at the Hanger Plate and screw it firmly. (Refer to Page 6 step B-3)
重新安裝吊架支架於吊板並將之鎖緊。(請參閱第 6 頁步驟 B-3)

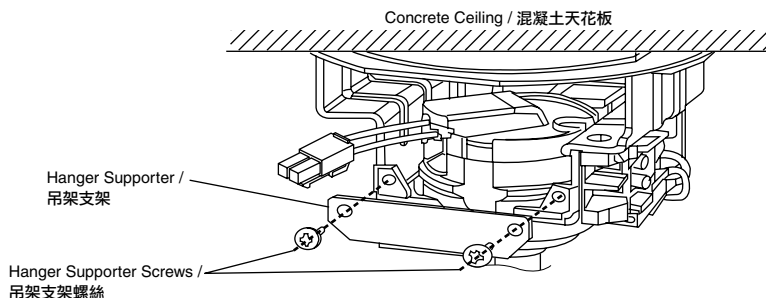

- 5** Join Connector A (from Motor Assembly) to Connector B (from Hanger Plate Assembly).
將連接器 A (從發動機組件) 連接至連接器 B (從吊板組件)。

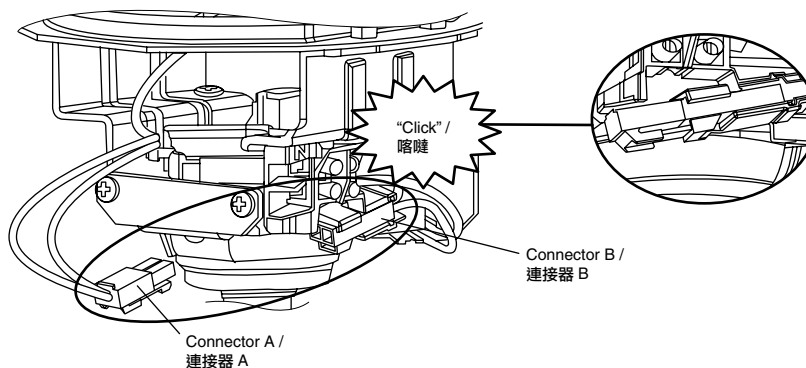

Check Point After Install / 安裝後的檢驗點

- | | Check / 檢查 |
|--|--------------------------|
| 1. Ensure the position of Ball Joint Holder is pressing on the top of the Switch Cover as shown.
(If the Ceiling Fan unable to operate due to misalign of the Ball Joint Holder, adjust the Ball Joint position until the holder is placed right on the top of the Switch Cover).
如圖所示，確定球形接頭固定點的位置壓在開關罩的頂端。
(若吊扇因為球形接頭固定點位移而無法操作，調整球形接頭的位置直至固定點位於開關罩的正頂端)。 | <input type="checkbox"/> |
| 2. Ensure the Hanger Supporter is screwed firmly to the Hanger Plate.
確定吊架支架已鎖緊至吊板。 | <input type="checkbox"/> |
| 3. The Safety Wire is securely fixed to the Carl Bolt and screwed to the Shaft.
將保險線固定至卡爾螺栓並鎖至轉動軸。 | <input type="checkbox"/> |

D) Wiring Instruction / 配線指示

- 1** Connect the wires to the house supply line according to diagram shown.
如圖所示將電線連接至家裏的電源線。
Please use splice if using Terminal for installation.
若使用端子進行安裝，請使用接頭。

⚠ WARNING / 警告



Electrical wiring must be done by competent personnel.
Can cause fire, electrical shock, Ceiling Fan drops and injuries.
電線配線工作必須由能勝任的人員進行。
可以導致火災、電擊、吊扇掉落及受傷。

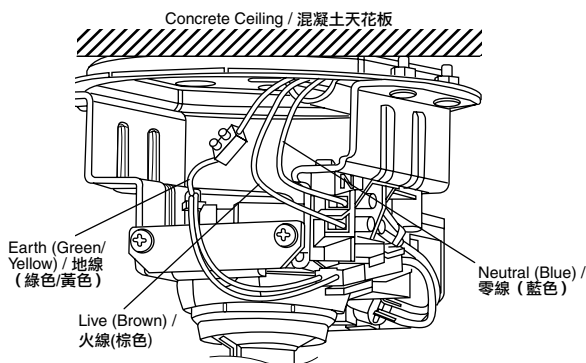

WIRING DIAGRAM / 電線圖

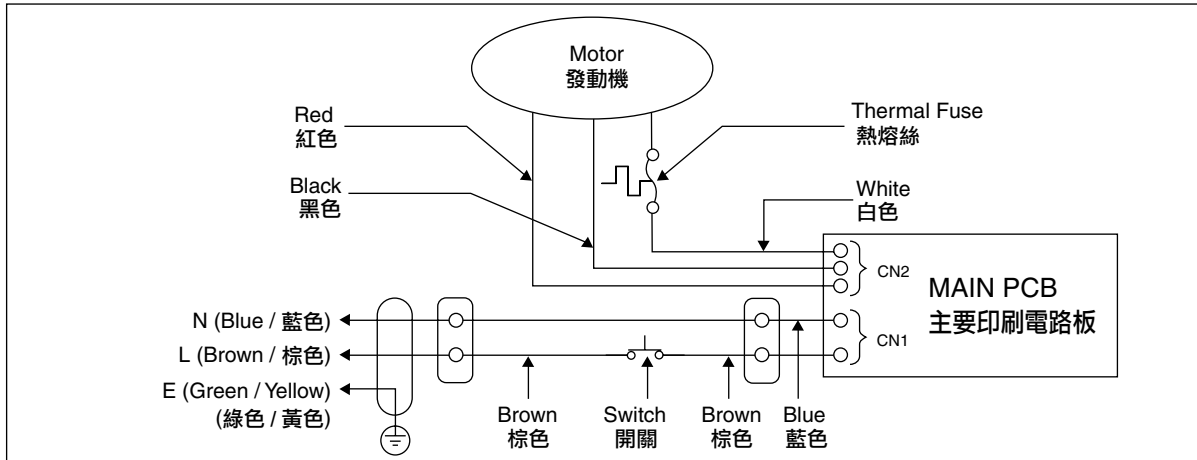

CONNECTING THE POWER SUPPLY / 連接電源

Only direct connection to wall switch is allowed. Please refer to figure below.
 只可以直接連接至牆壁開關。請參考下圖。

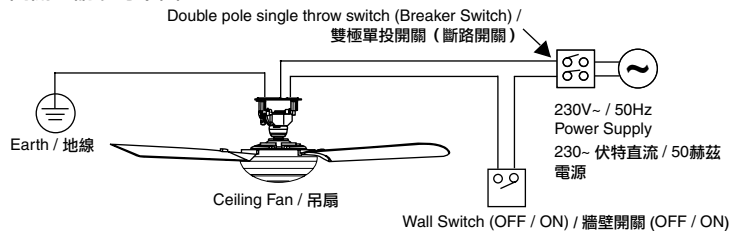

CAUTION / 注意



This product is not provided with cord and plug or with other means for disconnection from the supply. When connect or change the power cord or lead wire, it must be replaced by the qualified personnel in order to avoid hazard. Please use 227IEC53(RVV) or thickness of tube is 1mm or above. (Other requirements such as diameter of lead wire, please use according to the regulation of the country).
 此產品沒有提供電纜和插頭或其他用作接駁電源的附件。當連接或替換電纜或電線時，這項工作必須交由能勝任的人員執行以防危險。請使用 227IEC53(RVV) 或厚度超過1毫米的導管。(其他要求，例如電線直徑等等，請遵守相關國家的條例)。



This product should be installed with a double poles single throw switch (Breaker Switch) with minimum 3mm contact gap in the fixed installation circuit.
 Do not connect this Ceiling Fan to dimmer switch or regulator. (It can damage the Ceiling Fan)
 此產品必須在固定安裝電路上裝上觸點間隙為最少3毫米的雙極單投開關(斷路開關)。
 切勿將此吊扇連接至調光開關或調節器。(這會損壞吊扇)



Regulator / 調節器



Dimmer Switch / 調光開關



Should there be a dimmer switch or regulator, disconnect it and reconnect the wiring as below.
 若有調光開關或調節器，請按照下圖拆除然後重新連接。

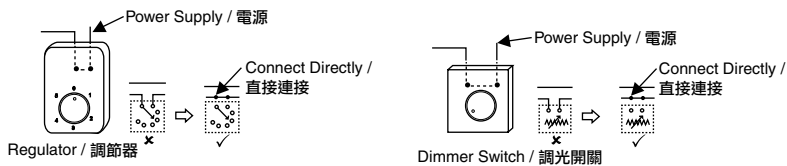

ATTENTION / 留意

It is recommended to user, to install an OFF/ON switch on the wall for the Ceiling Fan, replacing existing regulator or new regulator point. If your Remote Control missing or misplaced, the Ceiling Fan can be switched on at pre-set speed 2.
 建議用戶將吊扇的 OFF/ON 開關安裝在牆壁上，替換現有的調節器或新的調節點。若您的遙控器不見了，吊扇可以以預設速度 2 開啟。

E) Install Canopy to Motor Assembly / 安裝罩蓋至發動機組件

- 1** Remove the Screws, and separate Canopy as shown.
如圖所示拆除螺絲並分開罩蓋。

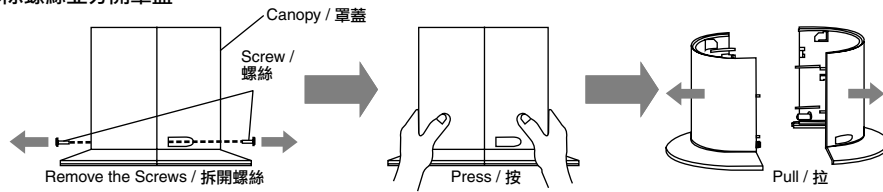

- 2** Take the Canopy (2 pieces) and place towards Hanger Plate Assembly as shown. (Canopy fixing direction follow to diagram as shown below.)
取罩蓋 (2 片) 並如圖所示朝吊板組件放置。(請遵循下圖所示的罩蓋安裝方向。)

Make sure Canopy is installed above Hanger Plate Assembly and clipped until the “click” sound is heard.
確定罩蓋被安裝在吊板組件之上並夾住直至聽到“喀噠”聲。

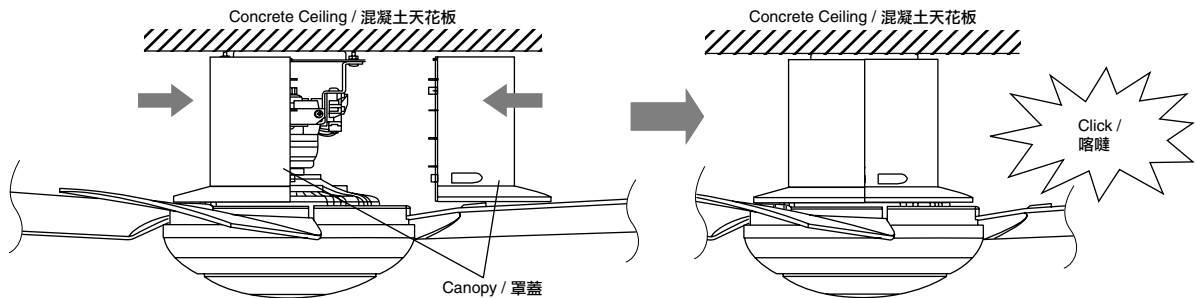
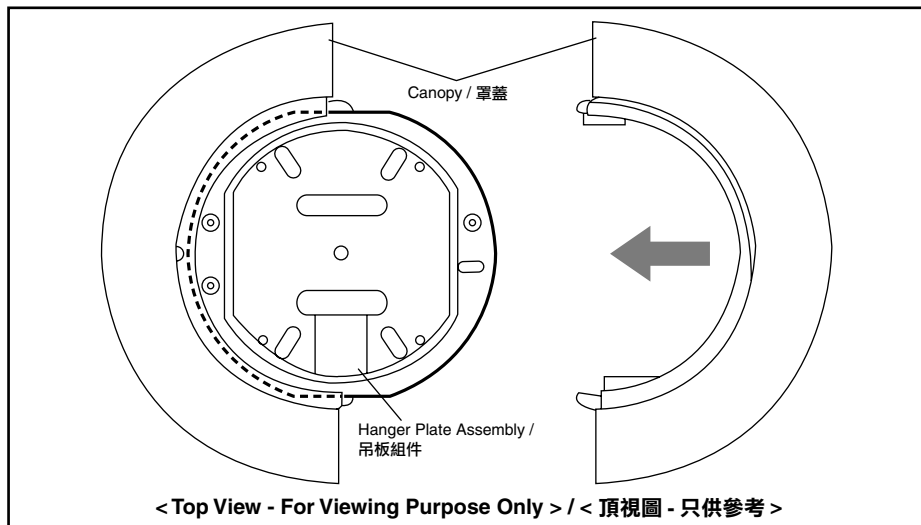

NOTE / 備註

Make sure Canopy installation follow as diagram shown. / 務必遵循圖示安裝罩蓋。
Can cause Canopy damage after screw fixing. / 鎖上螺絲後會導致罩蓋損壞。

- 3** Fix the Screws into the Canopy and tighten it firmly.
將螺絲鎖入罩蓋然後鎖緊。

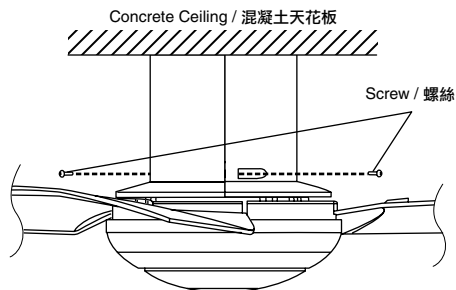

CAUTION / 注意



Do not assemble Canopy in this opposite direction.
Can cause abnormal noise.
切勿以反方向裝置罩蓋。
這會導致噪音。

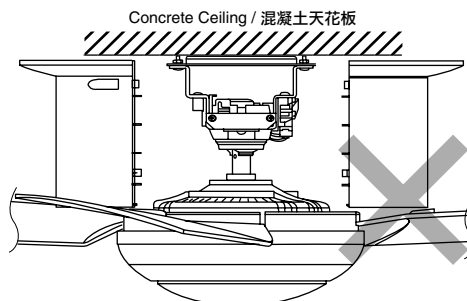

Do not clamp the wire after Canopy fixing.
Can cause fire, electric shock, Ceiling Fan drop and injury.
安裝罩蓋之後，切勿夾緊電線。
可以導致火災、電擊、吊扇掉落及受傷。

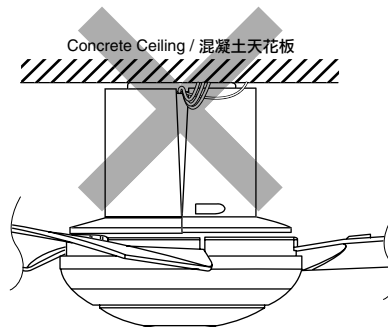

Check Point After Install / 安裝後的檢驗點

1. The Canopy is securely screwed. / 罩蓋已被穩固地鎖緊。

Check / 檢查

F) Install Remocon Holder to Wall / 安裝遙控器固定器至牆壁

Fix the Remocon Holder to wall as shown.

* The Wall Plugs are not needed for wooden walls.

如圖所示講遙控器固定器安裝在牆壁上。

* 木牆不需使用牆壁插座。

Remocon Holder / 遙控器固定器

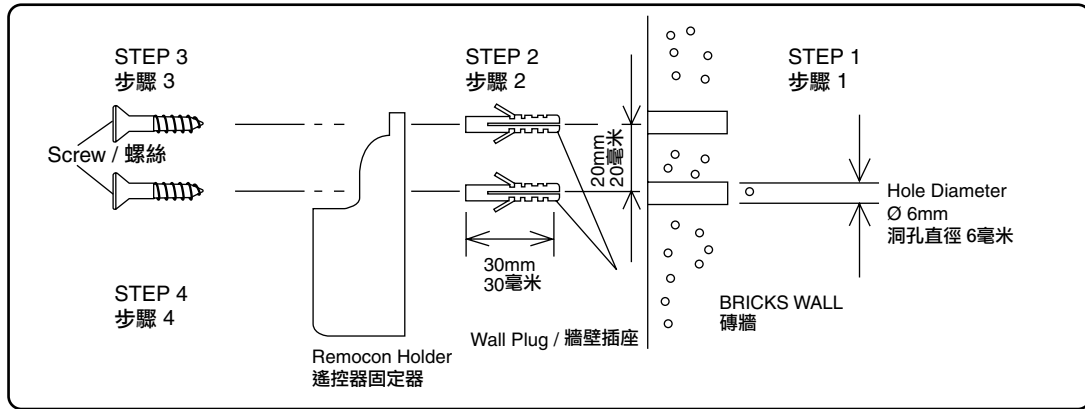

CAUTION / 注意



After installation make sure the Ceiling Fan does not wobble extremely.

Can cause injury if Ceiling Fan drops.

安裝後，請確定吊扇不會過度搖晃。

若吊扇掉落會導致受傷。

How To Use / 如何使用

A) Remote Control / 遙控器

- Insert 2 pieces AA, R6P, R6, LR6 size Batteries and make sure the polarity direction is as shown.
- Please remove all Batteries before disposing the Remote Control.
- The life of Battery is about one year for a normal usage.
- 插入2枚AA、R6P、R6、LR6電池，並確保電極方向如圖所示。
- 丟棄遙控器之前請拆除所有電池。
- 在正常使用下，電池的使用壽命是大約一年。

1. Remove the cover

- Pull the flap to remove.

打開蓋子

- 拉出蓋口開關瓣以拆除。

2. Insert the Battery (2 pieces: AA, R6P, R6, LR6)

- ⊕ ⊖ Position should match.

插入電池 (2 枚: AA、R6P、R6、LR6)

- ⊕ ⊖ 位置必須對稱。

3. Close the Cover

- Insert the protruding part (2 positions) into the Remote Control (2 holes), and press the flap.

蓋好蓋子

- 將突出的部分 (2 個位置) 插入遙控器 (2 個洞孔)，然後按下蓋口開關瓣。

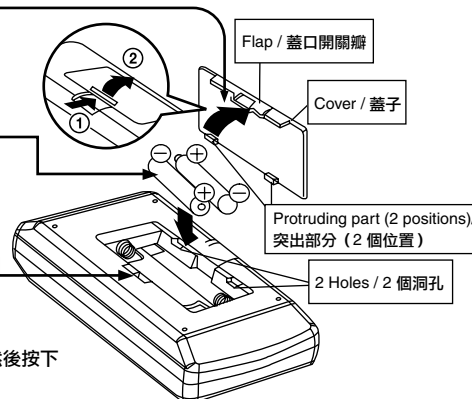

WARNING / 警告



Do not insert the metal item in the Battery area with the Battery.

Can cause fire, explosion, short circuit and electrical shock.

切勿把金屬物體與電池一起放入電池置放處。這可導致火災、爆炸、短路及電擊。

ATTENTION / 留意

- Please remove all Batteries before disposing the Remote Control.
- 棄置遙控器之前請取出所有電池。

B) Remote Control Coverage / 遙控器覆蓋

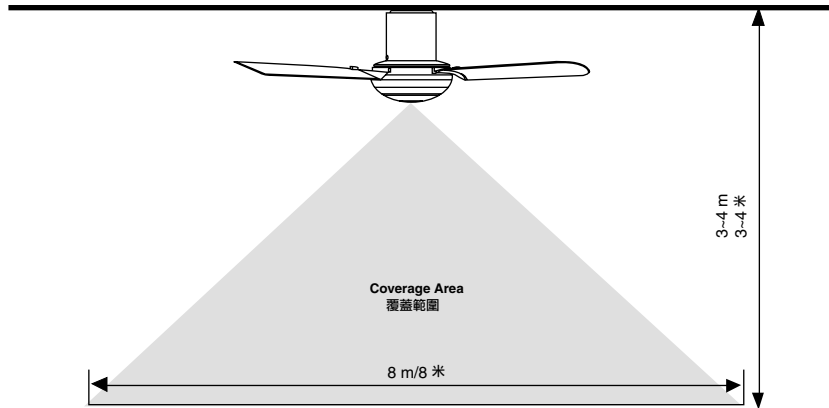

The Figure shows the best coverage area. The ideal ceiling height is 3~4m. The Remote Control must be pointed to the direction of the fan when in use.

圖顯示最佳覆蓋範圍。最佳天花板高度是 3~4 米。使用時，遙控器必須指向風扇的方向。

ATTENTION / 注意

The Power consumption when the operation is turned off by the Remote Control is about 1W.
It is recommended to switch off wall switch or breaker if Ceiling Fan is not in use for long period.
This is for zero power consumption purpose.

操作被遙控器關閉時的電源消耗是大約 1 瓦特。
若將長時間不使用吊扇，建議您關閉牆壁開關或斷路器。
以達到零電源消耗的目的。

C) How To Use Remote Control / 如何使用遙控器

OFF/ON Button / OFF/ON 鍵
Press OFF/ON button to activate or stop the Ceiling Fan.
'ON' - Short "Beeping" sound
'OFF' - Long "Beeping" sound
按 OFF/ON 鍵啟動或停止吊扇。
'ON' - 發出短促的“嗶”聲
'OFF' - 發出長長的“嗶”聲

OFF Timer / 關閉計時器
If 6 hours timer is ON (3 lights indication), the timer will gradually count down from 6 hours to 3 hours (2 lights indication) then 1 hour (1 light indication) until OFF (no light indication).
若開啟 6 小時的計時器 (3 個指示燈)，計時器將逐漸從 6 小時倒計至 3 小時 (2 個指示燈)，然後至 1 小時 (1 個指示燈) 到最後關閉 (沒有指示燈)。

Timer Cancel / 取消計時器
Push this button to cancel Sleep Mode or OFF Timer.
推此按鍵以取消睡眠模式或關閉計時器。

Speed Button / 速度鍵
3 speed control (Speed 1, 2, 3)
3 速控制 (速度 1 - 2 - 3)

Sleep Mode / 睡眠模式
Step 1: Select either speed 2* or 3**.
Step 2: Select either 3 hours or 6 hours timer.
Step 3: Press SLEEP MODE button and timer light indication at Ceiling Fan will blink. For Sleep Mode function refer to SLEEP MODE FUNCTION chart.
To cancel the Sleep Mode, press once more.
步驟 1: 選擇速度 2* 或 3**。
步驟 2: 選擇 3 小時或 6 小時的計時器。
步驟 3: 按睡眠模式按鍵，吊扇的計時器指示燈將閃爍。
有關睡眠模式的功能，請參閱睡眠模式功能圖表。
要取消睡眠模式，再按一次。

D) Timer And Sleep Mode / 計時器及睡眠模式

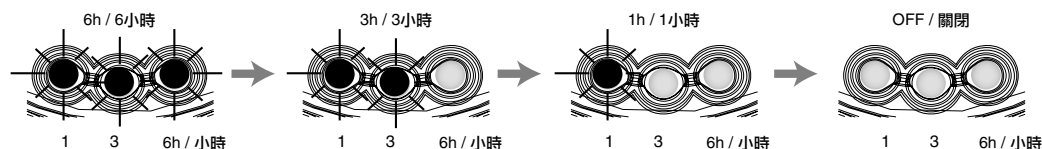

E) Sleep Mode Function / 睡眠模式功能

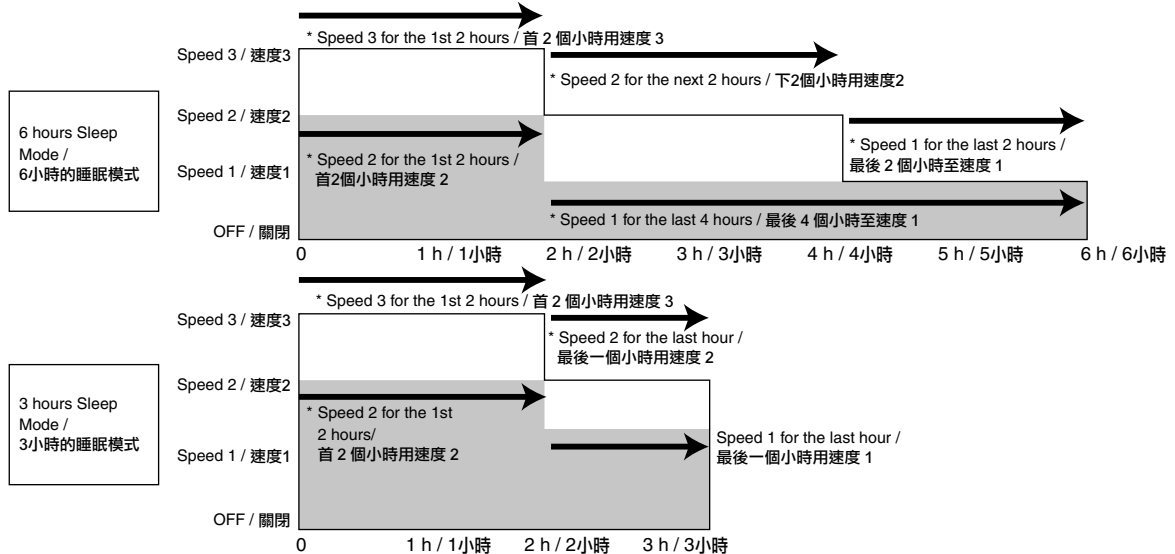

Sleep Mode functions for speed 2 and 3 only.
睡眠模式功能僅限速度 2 及 3。

Maintenance / 維修

GUIDE TO BETTER MAINTENANCE / 維修指南

- Check the fan condition annually. If a problem occurs, stop using the fan. Then refer to service, sales or maintenance shop.
Check points : Loosened Screws, Hexa Nut and Carl Bolt, Safety Wire condition, Motor Shaft damage, Hanger Plate Assembly etc.
每年檢查風扇的狀況。如果出現問題，停止使用有關風扇。然後質詢服務、銷售或維修商店。
檢驗點：螺絲松脫、六角形螺帽和卡爾螺栓、保險線狀況、發動機轉動軸損壞、吊板組件等等。
- Keep the fan clean. Wipe away dirt with a clean soft cloth, ordinary soap and water. Wipe it again to dry it. Do not use solvents (Gasoline or petrol).
* Please do not bend the Blade while cleaning.
保持風扇清潔。用乾淨的軟布、普通肥皂和水抹去汙跡。再抹一次將之抹乾。切勿使用溶劑（汽油或石油）。
* 清洗扇翼時請切勿折彎扇翼。
- Do not paint the Blades. If damage, order new set of Blades (3 pieces) from service shop or sales shop.
切勿為扇翼塗漆。若扇翼損壞了，請向服務商店或銷售商店訂購新的扇翼（3片）。
- When referring to service, sales or maintenance shop, show this instruction to them and maintain correctly.
當您質詢服務、銷售或維修商店時，請向他們出示此指示以便他們正確地進行維修。
- If the product is broken or damage, please remove the fan from ceiling and replace with a new fan. This is to avoid the Ceiling Fan drops.
若產品已折斷或損壞，請從天花板上拆除風扇，然後換上新的風扇。這是為了防止吊扇掉落。
- Recommendation for the fan suspension system shall be examined at least once every two years.
建議每兩年至少檢查風扇懸掛系統一次。

Product Specification / 產品規格

POWER INPUT 功率輸入	230V~ 50Hz				
WATTAGE 瓦特數	ROTATION (RPM) 旋轉度 (RPM)		AIR VELOCITY 風速	AIR DELIVERY 送風量	NET WEIGHT 淨重
	LOW 低	HIGH 高	m/min 米/分鐘	m ³ /min 立方米/分鐘	kg 公斤
54	119	248	190	160	5.1